

# Investment delivers a new dimension for FC Laser

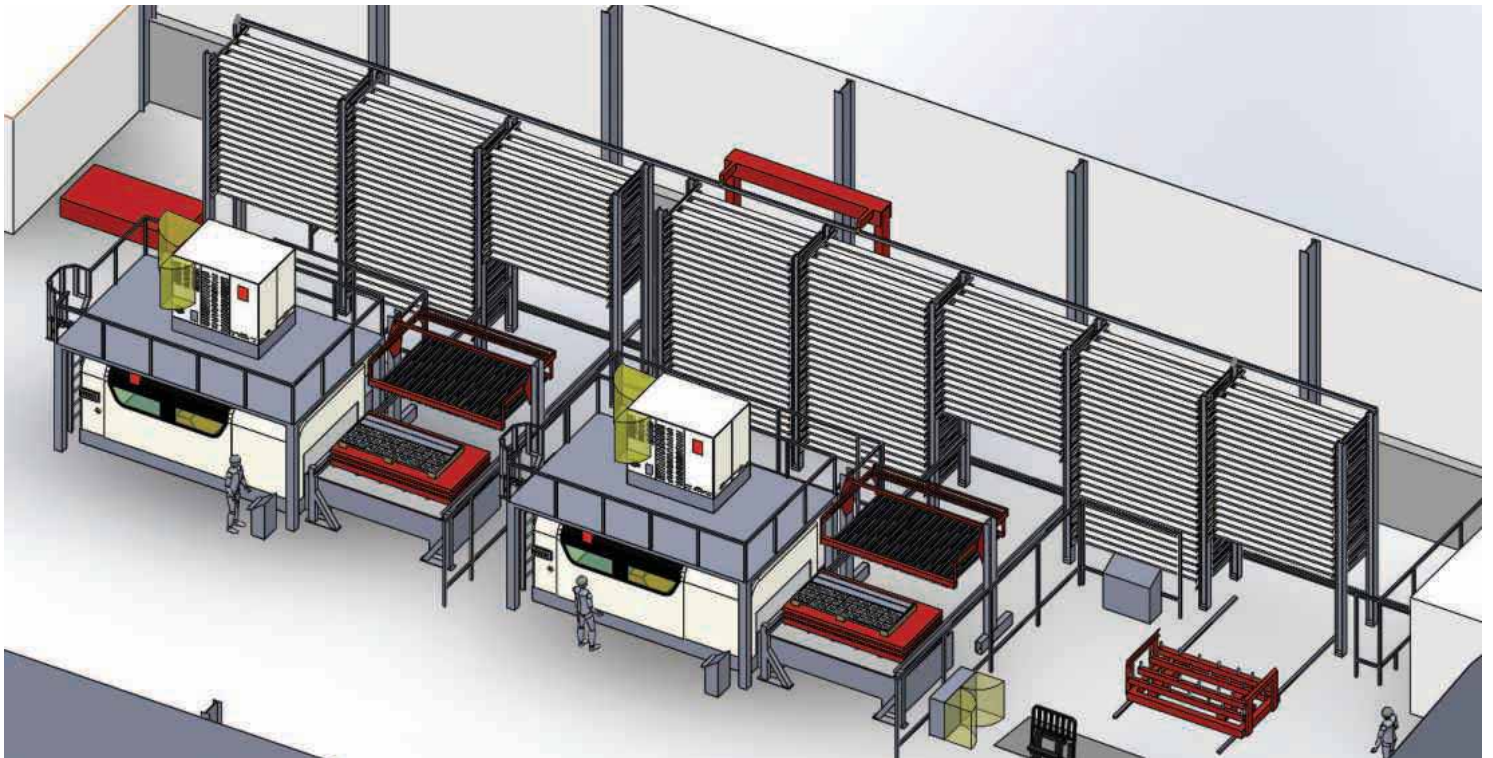

**Automated Precision Laser Cutting**

Contact FC Laser at: [sales@fclaser.co.uk](mailto:sales@fclaser.co.uk)

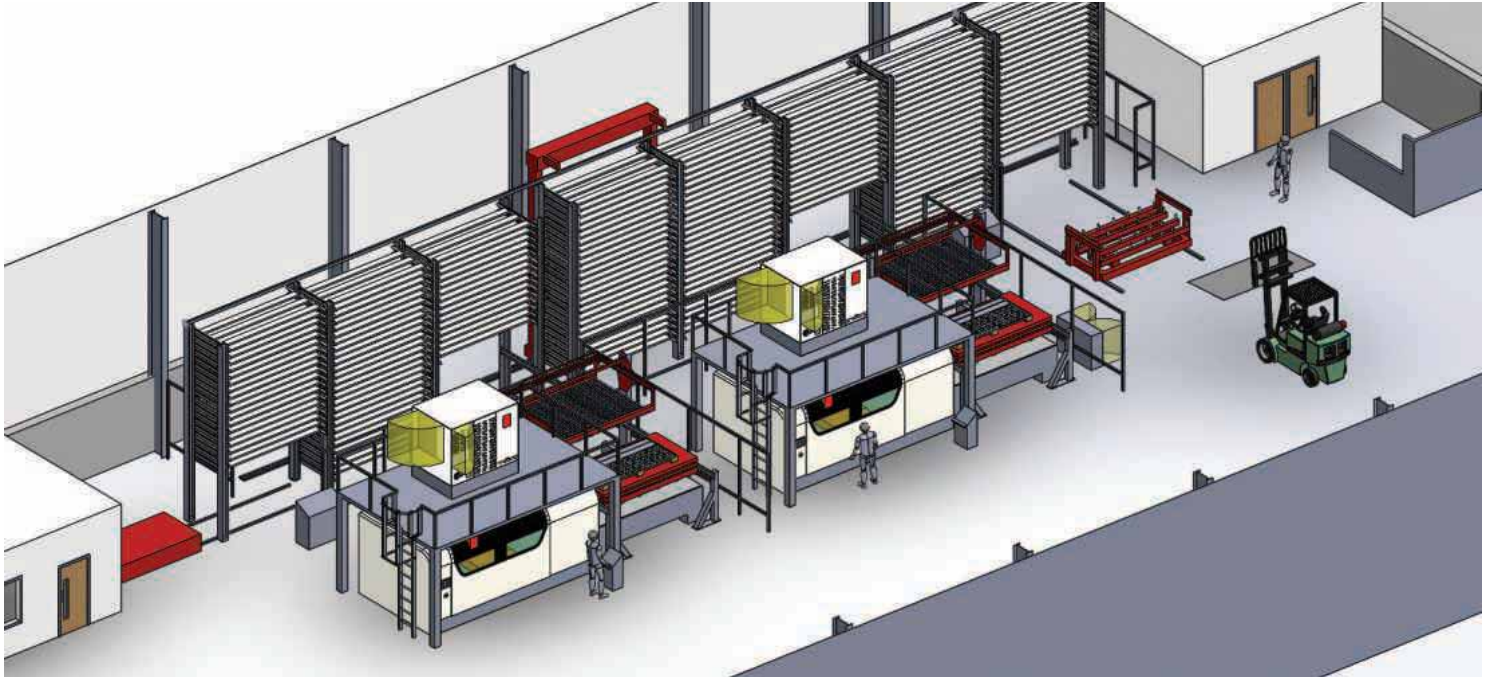

# The Next Generation ALPHA 3 AXIS CNC

- Next Generation control System Fanuc Oi-TF Plus
- Large working envelope
- Full interpolating C Axis and Driven Tools
- 3 Programming Methods incorporating the Iconic Alpha system, Fanuc Manual Guide i, G code ISO Programming



Scan here for an  
exclusive preview



CONTACT US ON +44 (0) 1924 415000  
or [info@colchester.co.uk](mailto:info@colchester.co.uk)





Visit our website at:  
[www.engineering subcontractor.com](http://www.engineering subcontractor.com)

CONTENTS

NEWS	4
MEDICAL REPORT	6
FEATURE - 5-AXIS MACHINING	10
METAL CUTTING	16
FEATURE - TOOLING & WORKHOLDING	20
MEASUREMENT & INSPECTION	26
ADVANCED MANUFACTURING	30
CADCAM	36
FEATURE - LASER CUTTING	40
FEATURE - SAWING & CUTTING OFF	46

**NEXT ISSUE SEPTEMBER**

- AUTOMATION
- AEROSPACE REPORT
- MEASUREMENT & INSPECTION
- WATERJET MACHINING
- WORKHOLDING

Published by Roger Barber Publishing  
Enterprise House, Foundry Lane, Horsham, West Sussex, RH13 5PX  
Tel: 01403 266022

Publisher: Roger Barber  
Email: [roger@rbpublishing.co.uk](mailto:roger@rbpublishing.co.uk)

Editor: John Barber - 01403 266022  
Email: [john@rbpublishing.co.uk](mailto:john@rbpublishing.co.uk)

Accounts: Jackie Barber - 01403 563791

Production manager: Anna Rodrigues - 01472 210712  
Email: [studio@rbpublishing.co.uk](mailto:studio@rbpublishing.co.uk)

Design & Production: Roger Barber Publishing  
Print: Holbrooks Printers Ltd, Portsmouth, Hampshire

Engineering Subcontractor is mailed to a controlled circulation of readers with a legitimate interest in the content. Roger Barber Publishing stores all business data securely and does not share with third parties.

No part of this publication may be reproduced without express written permission.

## Investment adds another dimension

FC Laser, the fastest growing precision laser cutting company in the UK, has committed to a significant and ambitious £2.5m investment plan, which will include a facility redesign with optimised layout, the introduction of two new 12 kW Bystronic ByStar Fiber lasers, a fully automated Tower Storage System and fully automated paint line.

This investment has already commenced, with the first 12 kW Laser already installed. The entire project will be completed including full operational capability by the end of 2020. This investment is testimony to the FC Laser team. Despite the challenging and unprecedented times, FC Laser is pushing forward with a significant and ambitious investment because of a great belief in its people, product and service offering to its customers.

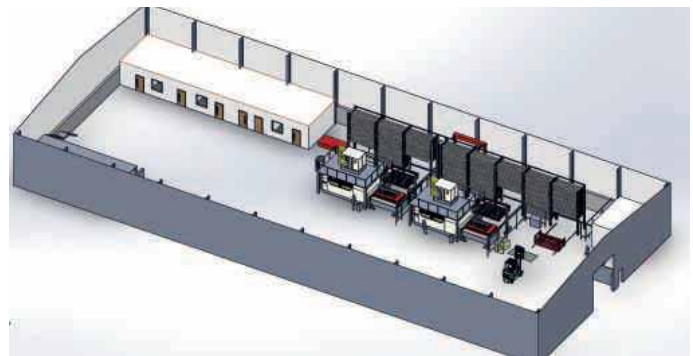

Managing director Danny Fantom comments: "Our innovation and dedication to customer service has been the key factor in our decision to commit to a significant investment in two ByStar 12 kW laser cutters and a brand new state-of-the-art automated Tower Storage System. Once installed we will be the only laser cutting company in the country to operate a fully automated Tower Storage System that is connected to two powerful 12 kW Lasers.

"This investment adds to our current laser cutting capabilities supporting and complementing our five Bystronic press brakes. If you include our top of the range tube laser and a new automated paint line, we believe we will have the most efficient, effective and comprehensive range of capabilities available in the marketplace today.

"The investment will allow us to become more efficient, which in turn will create a valuable window of opportunity to focus on the FC Laser "Ideal Team Player" philosophy. Additional staff training and development will further enhance our already skilled, talented and dedicated workforce. We will also continue our focus on talented people by inducting several apprentices on our successful apprenticeship scheme.

"We have always strived to give our customers the best possible service, by continuing to invest in our people as well as the best available technology and software we will ensure this continues."

**FC Laser**  
Tel: 0115 944 3428  
Email: [sales@fclaser.co.uk](mailto:sales@fclaser.co.uk)  
[www.fclaser.co.uk](http://www.fclaser.co.uk)

# Motivational time has united manufacturing industry

In the opinion of Citizen Machinery UK's managing director Edward James, the Covid-19 pandemic has united the whole of the manufacturing sector to an extent never seen before in terms of the levels of selfless application by huge numbers of people to boost production of much-needed medical equipment. In this article he describes how the company he runs, a turning solution provider, is contributing in the battle to deliver more ventilators to the front line in hospitals

Citizen became involved early on when it was contacted by the UK government's consortium for ventilator production, which became known as Ventilator Challenge UK. The committee included representatives from the AMRC (Advanced Manufacturing Research Centre) and Renishaw, who identified Citizen as the largest supplier of bar automatics in the UK and Ireland. This type of machine tool, especially the sliding-head variety with turn-milling capability, is critical to the rapid, efficient manufacture of components in very high volumes for making the extra ventilators needed by the NHS, 30,000 being the current target.

Accordingly, Citizen was given critical supplier status for the medical as well as the aerospace and defence sectors, although priority is being given to medical applications and is the only one being serviced at the moment.

At the outset, the government was considering building a factory to make ventilators parts and assemble them. However, we and others advising them



Edward James, managing director,  
Citizen Machinery UK Ltd

suggested that the best route would be to enlist the help of the existing pool of first-class manufacturers and their supply chains already using our lathes and production equipment from other leading machine tool suppliers.

I gave them a list of about 50 companies that use Citizen turning centres, choosing firms that operate sufficient numbers of machines, hold ISO accreditation and have the right level of expertise and metrology capability. We knew many of them already make ventilator parts as well as similar types of medical and non-medical parts out of both normal materials and special alloys.

We had told all of our customers via social media that Citizen Machinery UK was still open for business and continuing to operate under government guidelines to support customers and prioritise any request for help in producing medical components.

Nearly all the recommended contacts were approached by multinational firms, including Rolls-Royce, GKN and BAe, appointed by Ventilator Challenge UK to oversee supply chain management from purchasing through to ventilator assembly. The manufacturers were asked to change over their production to machining medical components and they immediately agreed to do so. As many of the firms recognised that additional capacity would be needed, it triggered multiple orders for new Citizen bar automatics from several companies and from additional manufacturers that became involved in the initiative through word-of-mouth recommendation.

In just over three weeks to mid-April 2020, 17 machines were prepared and delivered from stock, all of which are devoted to the production of medical parts. Transport is provided by Citizen's dedicated team, J Parrish & Son and, for the rest of April sliding-head lathe deliveries are running at one per day. Extraordinarily, each is commissioned and operating on a customer's shop floor in approximately 36 hours from receipt of the order, such is the urgency. Overlaid on this already hectic workload is a significant amount of



The CNC sliding-headstock turn-mill centre has proved to be the ideal machine tool platform on which to produce ventilator parts. Pictured is the Citizen Cincom D25-VIII LVF

re-purposing of existing turn-mill centres in the field to manufacture medical equipment.

There are examples of Citizen lathes having been reconfigured for making metal parts that are normally produced from stampings, forgings and castings. By far the largest proportion of resetting, however, has involved writing programs and providing tooling packages for turn-milling large quantities of plastic components from bar that are normally injection moulded, such as tubing connectors for ventilators. Often, they are supplied from overseas, including China, but deliveries may have either stopped or the numbers available are insufficient.

The six-week lead-time to produce a new injection mould tool is too long and the parts are needed much faster than that. Our multi-axis sliding-head bar autos are ideal for turning such components at both ends and milling and drilling them in the same cycle so they come off complete, without the need for special fixturing and with minimal material wastage.

It is actually a lot of work to identify parts that can be re-engineered in this way and then re-purpose a lathe to make them. A significant amount of CAD effort is required, plus complex CAM programming and post-processing.

Our applications department has been doing a lot of this in-house and at our customers' factories, outsourcing what it

cannot handle. One of our applications engineers has been working pro bono at a customer's site for three weeks to help out with re-engineering medical components due to staff shortage.

There are several reasons for Citizen fortunately finding itself in a good position to ship such a large number of lathes at short notice. One was the opening last year of a new turning centre of excellence in Brierley Hill with a showroom containing many demonstration machines. These together with those on show at the Bushey headquarters are available on short delivery.

The company in any case has a policy of supplying its machines and accessories from UK stock and more were available than usual, as extra had been brought in due to the possibility of a hard Brexit. Additional machines were in the UK, including some of the very latest models, ready to be shown at the now-postponed MACH exhibition.

Moreover, a bull run of sales had led to a backorder book of about eight weeks, with turning centres that were nearly ready for delivery able to be re-purposed at short notice and diverted urgently to medical component manufacturers. The original machine packages are being replaced from stock.

Naturally, these activities are only possible with healthy Citizen staff to implement them. Seeing the speed with which Covid-19 was spreading, we had pre-empted government advice by putting on hold in February all overseas travel, isolating the Bushey and Brierley Hill centres to avoid movement between them, and instigating working from home where feasible. The result is that of the 56 members of staff, 20 are furloughed but the other 36 are able to work, including all of the applications engineers, half of the service staff and many back office support personnel.

I am told that most of the turned parts have already been manufactured for the 30,000 extra ventilators, which is testament to the effort put in by us, other lathe suppliers and an army of willing and capable manufacturers in Britain and Ireland.

I would like to offer a big thank you to all our staff and suppliers who are helping to make this happen.

Everyone is volunteering to work tirelessly around the clock, at weekends and even through their holidays.

When the country finally comes through the pandemic, Citizen Machinery UK will find itself in a stronger position than previously as he predicts that demand for new machines will grow. It will be due to companies that are acquiring modern sliding-head turn-mill centres now, where in normal circumstances they would not have done so for several years, recognising earlier the benefits of the tighter tolerances and better surface finishes achievable compared with using their older lathes.

Additionally, most of the new turning centres currently being supplied have Citizen's proprietary LFV programmable chipbreaking software built into the control's operating system. Manufacturers are seeing the productivity benefits of this technology when machining traditionally long-chipping materials such as plastics, stainless-steel and titanium.

**Citizen Machinery UK Ltd**

**Tel: 01923 691500**

**Email: [sales@citizenmachinery.co.uk](mailto:sales@citizenmachinery.co.uk)**

**[www.citizenmachinery.co.uk](http://www.citizenmachinery.co.uk)**



**Hoffmann Group®**

**ENABLING UK MANUFACTURING  
AND BRITISH INDUSTRY**

**EXPECT  
MORE**

**MAKING YOU MORE SUCCESSFUL  
BY INCREASING PRODUCTIVITY  
AND REDUCING COSTS**

**Machining | Clamping | Metrology | Cutting and Grinding  
Hand Tools | Power Tools | Workstations and Storage  
Workshop Accessories and Consumables  
Personal Protective Equipment | Spill Control**

**Tel: 0121 716 4301  
Email: [ab.uk@hoffmann-group.com](mailto:ab.uk@hoffmann-group.com)**



# Traceability in the medical sector, a technical challenge

Accuracy, efficiency and safety are the key words of an industry at the cutting edge of technology. Governed by numerous standards ensuring the reliability of its components, the medical sector has implemented numerous traceability processes over the last few years.

Thanks to the markings applied to the various components, it is possible to obtain information about the manufacturer, but also the component reference number or their expiry date. All this data complies with the UDI (Unique Device Identification) and MDR (Medical Device Regulation) standards, which are essential for exporting devices to the USA and Europe.

The components to be marked are as diverse as the professions that make up the medical sector. There are, for example, many cases of marking on surgical instruments such as scalpels or bistouries, but also on prosthetics or orthoses, made of steel, cobalt, ceramics or biomaterials, dental implants, often made of titanium, or hearing aids or pacemakers.

To ensure optimal identification throughout their distribution and use, these multiple devices must have a marking composed of different elements. In order to comply with the standards mentioned above, it must contain a machine-readable barcode or Datamatrix as well as several alphanumeric codes that can be identified by humans. Quite often a logo is applied, meeting a need that is more aesthetic than practical.

In addition, there are many constraints linked to the complexity of the marked components and the sector of activity. For example, the materials with which the various devices are made are complex and varied (steel, titanium, stainless steel, ceramics, various alloys, biomaterials, etc.) and require real technical expertise when marking. Precision objects and medical tools are often small and leave very little space for marking. Despite the small marking windows, the identifiers must be contrasting and visible to allow reading via a vision system and a human.

Another challenge is not to weaken the part nor to change its surface state (essential for bone prosthetics which undergo



important efforts throughout their life span). It is also important to take into account all the surface treatments and sterilisation cycles that medical instruments undergo. It is therefore essential that the marking carried out is resistant and durable over time.

Benoit Massel, specialist of laser marking technology at SIC Marking explains: "All the difficulties of permanent marking by laser technology on medical parts lies in the ability to obtain a contrasting result without affecting the surface state of the material, which must resist passivation treatments. The technology must also be able to mark on a variety of materials, for example polymers, metals, etc."

### Laser marking, the most suitable solution for the medical sector

All these constraints make the traceability of medical tools a real technical challenge. This is why SIC Marking, a world leader in traceability solutions, is committed to providing the most appropriate marking solutions to meet all the challenges faced by the medical sector.

With more than 30 years of experience, SIC Marking has become an expert in laser marking. This latest generation technology consists of emitting radiation from a source, amplifying it and directing it towards the part to be marked. The beam creates a chemical reaction on contact with the workpiece.

This traceability solution, thanks to its many advantages, is becoming more and more widespread in the medical industry. It offers great flexibility of use and can mark barcodes, Datamatrix codes, alphanumeric characters and logos; all this while adapting to any material. The high-contrast and durable result obtained allows perfect reading over time for optimal traceability. Finally, laser marking ensures faultless security, because it doesn't weaken the part and doesn't degrade its hygiene - a crucial factor in the medical sector.

The SIC Marking laser product range can be adapted to your requirements, regardless of the type of marking, the parts, for serial or single marking. It consists of lasers that can be integrated with various options:

- 3D function for marking on complex shaped parts, different heights, curves or angled faces.
- Integrated Vision function for fast and reliable reading of barcodes and Datamatrix codes.
- Rotary D-axis for marking cylindrical workpieces around the diameter.
- The range is completed by three marking stations, the L-Box, XL-Box and the new XXL-Box.

SIC Marking provides a feasibility study before each project after collecting the needs of our customers via its representatives.

Nicolas Louison, technical sales representative, at SIC Marking says: "Today, the medical sector is a sector where traceability has become essential and necessary. SIC Marking's experience in this sector enables us to provide our customers with the most interesting marking solutions from a technical and economic point of view. Our wide range of laser marking

solutions enables us to offer our customers a marking system that meets the requirements of the various types of applications: permanent, non-destructive marking, resistant to the sterilisation process, etc."

### Numerous references

SIC Marking has many references in the medical sector, notably in Italy, with the company Mectron. A specialist for more than 40 years in the manufacture of inserts for clinical applications, it exports its products to more than 80 countries.

SIC Marking was approached with the exciting challenge of marking titanium instruments for dental surgery. The marking consisted of an alphanumeric code and a logo and should not, under any circumstances, weaken the parts, which were then subjected to ultrasonic treatment. The challenge was also to create an automatic laser marking system capable of working in collaboration with the latest generation of COBOT (Collaborative Robot).

This project allowed SIC Marking to once again prove its expertise, thanks to an

immediate understanding of the customer's needs and a technical solution proven and validated by electron microscope verification tests in the laboratory.

SIC Marking is also marking on ceramic prostheses, titanium inserts, steel bone fixators etc.

SIC Marking is an expert in marking and traceability for the automotive, aerospace, mechanical and energy sectors. The company has more than 300 employees worldwide with a turnover of €55m. The company operates in more than 50 countries and has nine subsidiaries. Its offering consists of standard and customised solutions in laser, dot-peen and scribing technologies as well as various associated services, i.e. customer support, spare parts, training, retrofit, maintenance contracts. SIC Marking has a customer-oriented culture and promotes operational excellence to enhance the customer experience.

### SIC Marking UK

**Tel: 01926 830372**

**Email: p.sidwell@sic-marking.com**

**www.sic-marking.com**

## Rental initiative for tough times

The COVID-19 outbreak has led to a significant resurgence in interest in Mills CNC's 'SMART Options' machine tool rental initiative amongst UK and Irish manufacturers.

Mills CNC, the exclusive distributor of Doosan machine tools in the UK and Ireland, has refreshed and relaunched its popular 'SMART Options' machine tool rental scheme in light of the coronavirus outbreak and a renewed demand for the scheme amongst UK and Irish manufacturers.

The rental scheme, available on all new Doosan machines supplied from stock by Mills, is administered and managed by Mills CNC Finance, the company's independently operated machine tool finance arm - and has, over recent years, helped a significant number of component manufacturers acquire a new Doosan machine tool.

The spread of the pandemic and the uncertainty it has created and continues to create has sparked new interest in the scheme.

Kevin Gilbert, Mills CNC's managing director says: "Our SMART Options rental scheme has always been available to

manufacturers, but interest and demand over the last few weeks, understandably, has increased exponentially.

"Despite the continuing lockdown and government instructions on social distancing, many component manufacturers are operational.

"Some of these companies are actively involved in manufacturing ventilators, ventilator components or other emergency medical equipment in response to the coronavirus and need immediate and additional short-term machining capacity and capabilities to help fulfil these orders."

Other component manufacturers, with one eye on the future and the inevitable relaxation of the lockdown, are preparing, admittedly with cautious optimism, for the future.

Kevin Gilbert continues: "Some companies need additional machining capacity but are reticent about saddling themselves with what they consider to be long-term financial commitments caused by investing in a new machine tool via a bank loan or via traditional Hire Purchase or Operating Lease arrangements. For these



companies SMART Options is more than a viable alternative."

The SMART Options Rental Scheme is flexible and is designed to bridge the gap between manufacturers needing access to high-performance machining capability and capacity but who do not want to 'break the bank' acquiring it.

"SMART Options is yet another example of Mills CNC having its finger on the pulse... of understanding market dynamics and needs...and of doing everything it can to make customers' lives easier in these difficult times," concludes Kevin Gilbert.

All Doosan machines held in stock by Mills CNC at its Leamington facility, including the company's best-selling Lynx and Puma lathes and DNM vertical machining centres, can be acquired through the SMART Options scheme.

### Mills CNC Ltd

**Tel: 01926 736736**

**Email: sales@millsnc.co.uk**

**www.millsnc.co.uk**

# VISI expansion helps medical manufacturer in COVID-19 fight

Free temporary licence enables XL Precision to increase production immediately

Expanding its suite of VISI software has enabled a medical components specialist to increase its capacity by up to 40 percent, dedicating that additional production to manufacturing parts to fight COVID-19.

XL Precision Technologies already produces components for respiratory devices, but saw how existing customers and other medical companies may need more support, more quickly, as Coronavirus took hold.

A free temporary licence from VISI enabled it to start increasing capacity immediately while an internal capital expenditure was set up and the administration process of purchasing additional seats completed.

"We'd been planning a £300,000 investment in software during the next three years, but this emergency highlighted how valuable it is and made us realise that, if we had more seats of VISI, we'd be even more effective in introducing new products," says managing director Tom Graham. "We had licences to allow three people to work with VISI at any one time, while I have six engineers who I could dedicate to it."

Customers tell the company one of its key USPs is its ability to turn projects around quickly. Tom Graham continues: "We're in steady production most of the time but a lot of what we do is development support and a fast turn-around of small batches of products. The Government's call for product support against COVID-19 has led to a completely different set of circumstances, where customers potentially need thousands of components within days of ordering them."

Having the free 30-day licences from VISI meant that it was able to immediately dedicate increased production capacity to the new COVID-19 component runs. "We



identified the machines required, and because we have the appropriate VISI CAD/CAM software our engineers were able to convert customers' drawings to a proper CAD design and create laser cutting, milling and EDM wire machine programs," explains Tom Graham.

XL Precision Technologies has used VISI universally across the whole of its development and production process for several years. "Essentially, we manufacture to customers' designs. Sometimes those designs aren't optimised for manufacture, so we use VISI's modelling package to redesign it, or come up with new ideas. We also use the modelling capability online, where we'll have a conference call and share our models with the customer's engineers, wherever they are in the world.

"This is proving to be particularly valuable for getting quick approval on these new COVID-19 components. It was really vital that these parts go into production as quickly as possible, so VISI is playing a vital role in the battle to save people's lives from this global virus," concludes Tom Graham.

Once the designs are approved, they use whichever software element is required to prepare NC code for the relevant machine tool. As well as their increased work on components to fight COVID-19, they are continuing to produce parts for elective surgery customers, as hospitals, doctors and surgeons still need the completed devices and instruments to carry out emergency treatment.

While the free 30-day license from VISI enabled XL Precision to bring the CAD/CAM expansion forward immediately, the rest of its planned £300,000 investment over the next three years includes program management and quality software.

Hexagon is a global leader in sensor, software and autonomous solutions. It puts data to work to boost efficiency, productivity, and quality across industrial, manufacturing, infrastructure, safety, and mobility applications.

Its technologies are shaping urban and production ecosystems to become increasingly connected and autonomous, ensuring a scalable, sustainable future.

Hexagon's Manufacturing Intelligence division provides solutions that utilise data from design and engineering, production and metrology to make manufacturing smarter. For more information, visit [www.visicadcam.com](http://www.visicadcam.com) or contact:

**Hexagon Manufacturing Intelligence**  
Tel: 01242 542040  
[www.hexagonmi.com](http://www.hexagonmi.com)

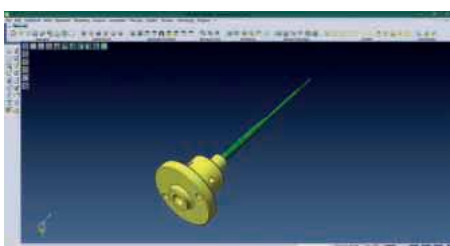



## Hoffmann Group UK launches remote consultation service

Hoffmann Group UK, Europe's leading system partner for quality tools, workstations and personal protective equipment (PPE), announced last month the launch of its remote consultation offering to support manufacturers keeping the UK running during the COVID-19 epidemic.

Using a suite of digital technologies, such as Microsoft Teams and Skype, manufacturers can enlist the support of a specialist consultant remotely. With the aid of these technologies, manufacturers can bring the consultant directly into their existing workspaces to make bespoke recommendations in areas such as material types and machining optimisation, driving greater levels of efficiency on the factory floor across various fields of manufacture, such as aerospace and automotive.

Tim Paddison, managing director of Hoffmann Group UK, says: "Like many organisations, we have had to assess how we can best maintain service levels to customers during this unprecedented situation. The manufacturing industry has a crucial role to play in the ongoing fight

against COVID-19, assisting the emergency production of ventilators for the NHS being a prime example.

"Our industry is among the hardest-hit by the outbreak and one being relied upon to provide the solutions needed to keep the UK both safe and working. With the challenges facing the sector, it has never been more crucial for us to come together and create new, innovative ways to share our expertise with each other and ensure our industry can overcome present disruption and not just survive, but thrive, in the months to come."

Through this service, Hoffmann supports manufacturers in both refining their existing processes and creating new specifications and workflows that optimise both efficiency and productivity.

The remote consultation service is open to all manufacturing businesses that are continuing to operate throughout the COVID-19 outbreak and providing additional support in areas such as pivoting to ventilator production. These businesses will be able to benefit from experienced



consultants' extensive knowledge base around how best to adapt existing machinery and equipment to produce components that will be used in medical equipment.

Hoffmann Group UK is the fully-owned UK subsidiary of the Hoffmann Group. As Europe's leading system partner for quality tools, the Hoffmann Group combines commercial expertise with both manufacturing and service competence.

**Hoffmann Group UK**  
**Tel: 0121 716 4301**  
**Email: [ab.uk@hoffmann-group.com](mailto:ab.uk@hoffmann-group.com)**  
**[www.hoffmann-group.com](http://www.hoffmann-group.com)**

## McLaren Racing relies on Ceratizit tooling and knowledge to support ventilator production

McLaren Racing is one of the members in the consortium of high-tech engineering companies, including Airbus, Rolls-Royce, BAE Systems, as well other Formula One teams, who have come together to meet the UK Government's Ventilator Challenge UK. The aim of which is to develop and build as many ventilators as possible for the National Health Service and beyond. To assist in meeting this challenge McLaren Racing has enlisted the expertise and cutting tool technology on offer from Ceratizit UK & Ireland.

The consortium has been awarded a significant order to produce 10,000+ ventilators, made up of two models currently manufactured by Smiths Medical of Luton and Oxfordshire-based Penlon. As part of the supply chain, Ceratizit UK & Ireland is being called upon to step up and support this endeavour as best they can.

Ceratizit had already announced a series of measures to support these activities and were happy to contribute when approached by McLaren Racing. Initial tooling requirements have been from the Ceratizit drilling range, with high performance drills

provided to produce accurate holes, up to 16xD, in both aluminium and steel. These have been supported with technical input from Ceratizit's industry solutions engineer Michael May and technical sales engineer Bob Thompson.

"McLaren Racing is one of several customers that we have been working with on the ventilator initiative, where we are able to help by ensuring they have the right tools when they need them, along with support and expertise we can provide," says Michael May. "While the initial requirement was for drilling tools, we have made many recommendations across a series of approximately fifteen components, to help improve production of these vital parts. The situation is one that is constantly changing, we will be supplying whatever is required, such as our AluLine end mills, PCR-AL plunge milling cutters, CCR-AL CircularLine end mills, alongside the WTX-AL & WTX-Ti drills."

"As a country we must do everything we can to fight this pandemic and, as an industry we are well placed to help lead that fight, so our offers of help for any



manufacturing company involved in the production of ventilator and associated diagnostic equipment will remain in place for as long as it is needed. If you need our help it is there for you," says Tony Pennington, managing director, Ceratizit UK & Ireland.

**Ceratizit UK & Ireland Ltd**  
**Tel: 0800 073 20373**  
**Email: [tony.pennington@ceratizit.com](mailto:tony.pennington@ceratizit.com)**  
**[www.ceratizit.com](http://www.ceratizit.com)**

# Subcontractor continues to expand, invest and automate

Founded in 1984 and having moved repeatedly to larger premises to cope with almost continuous growth in turnover, subcontractor Norjon Precision Engineering expanded yet again at the end of 2018 with the acquisition of an adjacent unit on the Quay West Business Centre in Gosport, which enlarged the factory to 17,500 sq ft. The firm has also invested substantial sums year on year, with £2 million spent during 2018 and 2019 and £1.2 million of capital plant on order for delivery during the first quarter of 2020.

A pivotal moment in the accelerating rate of Norjon's development was the decision in 2016 by owner and managing director Kevin Fox to automate a large proportion of production. The latest machine acquisition was a Hermle C 400 5-axis milling centre fitted with the manufacturer's HS Flex automated storage and retrieval system for eight 500 x 400 mm pallets. The turnkey cell, with touch-screen control for smart order management and connectivity for remote monitoring, was supplied in October 2019 by UK, Ireland and Middle East agent Kingsbury.

It joined two automated Hermle 5-axis cells delivered in 2018, a C 22 U and a C 12 U, both equipped with Erowa storage systems for exchanging smaller pallets. A further Hermle C 12 U is to be delivered in February 2020 equipped with a Dutch-made Halter robotic system for automated component loading and unloading around the clock, initially of vehicle engine parts. In total, taking into account three Hermles bought in 2017 and 2018 and legacy models from 2007 and 2012, plus a mill-turn C 42 U previously used by the AMRC and a larger C 52 MT mill-turn with a one-metre table due to arrive in March 2020, Norjon operates nine of these German-built 5-axis machines with a further two on their way from Kingsbury.

Kevin Fox comments: "In 2016 we often made batches of six-off prismatic parts of fairly high complexity. Even though we are a long-time user of 5-axis equipment, which helps to make components in one hit and mitigate some of the time and cost of manufacture, it was easy to lose money on those jobs with all the programming and



Kevin Fox, owner and managing director of Norjon Precision Engineering with one of Norjon's machine operators in front of the Hermle C 400 HS Flex multi-pallet cell at Gosport

setting that was needed. So we took the decision three years ago to go after contracts for much larger batches of components, more like 50- or 60-off, but still complex in nature requiring substantial machining time.

"Then one of our established customers in the medical industry ordered larger volumes of parts that we were already making. It was the trigger for us to move towards automation with the purchase of the first Hermle 5-axis cell."

The latest automated cell comprising the C 400 and HS Flex has been installed in the factory extension together with the existing C 20 and a spark eroder. With storage for eight pallets on four levels and extended tool capacity totalling 81 positions, the Hermle was purchased to fulfil a contract requiring the delivery of 10 assemblies per week for a customer in the automotive industry. The two parts, towards the larger end of components produced, require 10 hours' and 5 hours' machining respectively from solid aluminium and were initially milled and drilled on an unautomated C 400. Considerable extra capacity has been gained due to the HS Flex running unattended for long periods.

Norjon now concentrates on working for



A view of the robotic transfer arm that moves pallets automatically between the workpiece load/unload station in the background, their storage positions and the Hermle C 400's working area

four large corporations in the medical, food, automotive and marine propulsion industries. In the case of the latter sector, it has recently become a preferred supplier to BAe Systems Maritime, which was the reason for installing the first Hermle mill-turn centre. The new C 52 MT will extend mill-turn capacity to nominally one metre cube.

**Kingsbury**  
**Tel: 023 9258 0371**  
**Email: solutions@kingsburyuk.com**  
**www.kingsburyuk.com**

# BOOST PRODUCTIVITY

Increase the performance of your shop-floor with this incredible, limited offer on our best-selling HCN series 4000 and 5000 models, designed for unsurpassed productivity.



HCN-4000 AND HCN-5000

## Mazak

GREAT REWARDS\*  
WHEN SHOPPING  
WITH MAZAK

- THE FASTEST CNC IN THE WORLD
- UP TO 40% INCREASED PRODUCTIVITY
- COMPACT FOOTPRINT,  
LARGE WORKING ENVELOPE
- HIGHEST ACCURACY
- FULL ONLINE TRAINING AND SUPPORT
- FLEXIBLE FINANCE OPTIONS AVAILABLE
- EASE OF INSTALLATION

THANK YOU

\* OFFER ENDS 30/09/20

## INCREASED PRODUCTIVITY IMPROVED MARGINS

Bestselling solutions for high speed machining of multiple workpieces mounted on large multiple surface fixtures. Reduced changeover times due to the world's most intelligent, interactive, touch screen SmoothG control system.

The HCN series is designed with a high-rigidity construction which ensures improved cutting performance even at high-speed feed rates. Equipped as standard with a 2-Pallet Changer or with a range of flexible automation solutions, these models allow for simultaneous set up and machining of separate workpieces, increasing your productivity to the next level to ensure you become best in class.

Call +44 (0) 1905 755 755 or email [info@mazak.co.uk](mailto:info@mazak.co.uk)

DISCOVER **MORE** WITH MAZAK™

[www.mazakeu.co.uk](http://www.mazakeu.co.uk)



No app required – just use your mobile camera

**Mazak**  
Your Partner for Innovation



# DMG MORI helps BT Lerson transform its aerospace business

Operating from its brand new 15,000 sq ft facility on the doorstep of Stansted Airport, BT Lerson is working in partnership with DMG MORI, benefiting from the capabilities of the machine tools themselves and the technical support, training and contacts the collaboration brings, to make a step change in its business.

Although 70 percent of its work is in the aerospace and defence sectors, it also serves the oil and gas and pharmaceutical industries. Started in 1980, it made the move into CNC in the early 2000s and changed its business model to concentrate on higher value parts in 2010, achieving AS9100 status in 2014.

The company's first 5-axis DMG MORI machine, a DMU 50 was purchased preowned. Collaborating with DMG MORI helped it to get to grips with the 5-axis technology. The machine was refurbished by DMG MORI, marking the beginning of a close partnership. This was soon followed by a DMU 40 Evo with Erowa automation in 2014, a DMU 60 Evo linear with 3R automation in 2016 and two NLX 2500/700 in 2018 and 2019.

Julian Bedford, managing director at BT Lerson, says, "5-axis technology is more demanding, and it was a big learning curve for us, but we soon saw the benefits of the investments as cycle times were slashed, and product quality increased dramatically. We also recognised the need for automation, to enable us to get more from



the machines, people and skills that we have."

DMG MORI supplied turnkey automated systems to BT Lerson. "We were early adopters of automation and the cost was easily recovered within two years. If we had not invested, we would have needed three conventional machines to produce the same output with all the implications of extra labour, much more floor space and more work in progress. Going forward, we now consider that automation is essential." The

company monitors its machine performance and the automated machines run at over 90 percent OEE.

The 3R system has 60 pallets and the Erowa system has up to 24 pallets. BT Lerson sets up a series of different jobs to match demand. It also sets up sister tooling where long machining times are called for and uses the DMG MORI tool life management to switch tools automatically, enabling the machines to run unmanned for most of the time.

The two DMG MORI NLX 2500/700s replaced previous machines and have a bar feeder and parts catcher to produce parts up to 80 mm diameter. For bigger parts, the chuck can produce parts up to 366 mm diameter. Julian Bedford says: "These are fantastic machines and have changed the way we do turn/mill. They are so robust and thermally consistent that there is very little deterioration in tolerance. We can now reliably run unmanned for 24 hours with tight tolerance parts. We have also invested in DMG MORI gear cutting software on the machines, often reducing the process from five operations to two."

All the DMG MORI machines are covered by a five-year service and preventative maintenance plan and the company is



planning to extend it to other machinery in the factory. BT Lerson also used DMG MORI finance for the NLX machines. "The finance was very competitive and flexible with many favourable options such as, deferred payments and balloon payments," says Julian Bedford.

Formerly BTL Precision, BT Lerson acquired Lerson Fabrications, which is a preferred supplier to Stansted Airport and its supply chain and moved to its new location at the end of 2019. Julian Bedford, says, "The move to the new factory is several steps up in our working environment and has a big impact on customer confidence. Aerospace customers see that we have DMG MORI machine tools, properly monitored in a professional environment and are immediately reassured. They are trying to build long term relationships with good and competent companies as part of their supply chain and our aim is to expand towards more in depth and earlier involvement with these customers where, high quality and competitive pricing are the key considerations. We are already 30 percent up on the previous year."

BT Lerson is building on its relationship with Stansted Airport and bringing its fabrications business to AS9100 standards too. Julian Bedford is a governor at Harlow College, where DMG MORI has a presence. The college is currently involved in a project at the airport which is due to expand significantly. Julian is also involved in a digitalisation project at Cambridge University, so he is evaluating how this can be implemented at BT Lerson. Similarly, he finds that meeting other DMG MORI users is useful, sharing skills and building relationships for mutual benefit.

Julian Bedford concludes, "Working in partnership with DMG MORI has definitely led to new business and is enabling us to



reinforce long term relationships with our customers. A strategy of collaboration and cooperation at all levels of the business combined with technical excellence from DMG MORI has transformed how we operate."

**DMG MORI UK**  
**Tel: 024 76 516137**  
**Email: [steve.finn@dmgmori.com](mailto:steve.finn@dmgmori.com)**  
**[www.dmgmori.com](http://www.dmgmori.com)**

## The dynamic duo

Mills CNC, the exclusive distributor of Doosan machine tools in the UK and Ireland, has increased its 5-axis machining centre range with the introduction of two new Doosan DVF models.

The DVF 6500 (650 mm diameter table) and the larger capacity DVF 8000 (800 mm diameter table) are from the same stable as the highly popular Doosan DVF 5000 machine successfully launched in the UK and Ireland 18 months ago.

The new DVF machines share many similarities. Both machines are compact and have a rigid and stable structure for increased accuracies, improved surface finishes and greater process reliability. They are also fast, boasting impressive 45m/min rapid rates, and are equipped with powerful, oil-cooled, directly-driven BT40 spindles up to 22 kW/18,000 rpm, that deliver excellent cutting performance, irrespective of whether 3 + 2, 4 + 1 or full 5-axis simultaneous machining is the order of the day.

The machines also feature servo-driven

automatic tool changers with up to 120 tools, with a 1.3 second T-T-T changeover time that increase the machines' flexibility, roller LM guideways that deliver increased speed, accuracy and reliability, plus direct-drive rotary tilting tables (A-axis = +120/-120 degrees; C-axis = 360 degrees).

The DVF 6500 and DVF 8000 machines can be supplied with a choice of control: FANUC 31iB5, Heidenhain TNC640 or Siemens 840D with ShopMill software, and are supplied with thermal compensation systems (spindle and structure) and a long-life, grease lubrication system. A Collision Protection System can also be supplied as an option.

Both machines can also be supplied with a range of different automation solutions that increase their productivity and enable manufacturers to take advantage of unattended and lights-out operations.

The DVF 6500 and DVF 8000 have different-sized travels (DVF 6500 = 750 mm x 785 mm x 600 mm: X-, Y- and Z-axis; DVF 8000 = 1,000 mm x 900 mm x 685 mm:



X-, Y- and Z-axis) and different table loads of up to 1,000 kg and 1,400 kg respectively.

Within the DVF 8000 range a specific 'Turning' model can be specified. The DVF 8000T, with its integrated function, has the same technical specification as the DVF 8000 in most respects except for a lighter maximum table load of 700 kg and a faster C-axis feed rate of 600 rpm.

**Mills CNC Ltd**  
**Tel: 01926 736736**  
**Email: [sales@millsnc.co.uk](mailto:sales@millsnc.co.uk)**  
**[www.millsnc.co.uk](http://www.millsnc.co.uk)**



# Pumping up the volume

5-axis machining centre produces pump operations in two operations instead of five

A fundamental change to the way stainless steel pump bodies are machined by subcontractor Metaltech Precision Engineers is resulting in far-reaching benefits. They include a drastic reduction in setup time that lowers economical batch size by a factor of four, shorter lead times, faster cycles, savings in the cost of tooling and less wear on the machine tool.

Additional advantages of the new production route are reductions in power consumption and in space taken up on the shop floor. Both are in short supply at the firm's Hailsham factory and were the main drivers of the company's desire to find an alternative manufacturing process.

Expensive, 500 mm or 630 mm twin-pallet, 50-taper horizontal machining centres (HMCs) with box ways and high spindle torque, of which there are nine on site, together with CNC lathes, have underpinned pump body production since the company was established in 1976. The components are typically produced in five operations on three machines.

A German-built Spinner U-620 40-taper, 5-axis, vertical-spindle machining centre without a pallet changer, supplied as a turnkey package by sole UK agent



The German-built Spinner U-620 machining centre on the shop floor at Metaltech. It is the first 5-axis machine on site and the first machine to be supplied by Whitehouse Machine Tools to the Hailsham subcontractor

Whitehouse Machine Tools, now machines the components in two operations. Installed and operational within one week during November 2019, the cell heralds a

progression at Metaltech from the use of raw power to smart machining methodology.

The pump bodies in question, of which there are eight types ranging in diameter from 160 to 280 mm with numerous different port details, are produced for a customer in batches of 50 to 60 to a monthly schedule that might include as many as 15 component variants. Sometimes orders were impossible to fulfil and discussions had to take place regarding alterations to the schedule. That was because the traditional machining process takes 10 to 15 hours to set up.

After skimming the back face of a 316 stainless steel casting, it involves roughing the same face on an HMC and then roughing the front face, bores and ports on the same machine. The part is transferred to a lathe to turn the port details using single-tip boring bars. It then returns to an HMC to re-skim either the front or back face to provide a location for mounting the part on a window fixture to finish-machine both faces. Production of a batch of 50 to 60 bodies takes four weeks by this method.

In contrast, setup on the Spinner takes just one hour and the new process route is



A pneumatically actuated SCHUNK zero-point fixturing system ensures speedy changeover between operations on the Spinner



completed in two clampings, which means that 10- to 15-off can now be produced economically. In the first operation, roughing and finishing of the back face and the interpolated bores are carried out by respective 16 mm diameter, solid carbide end mills from MA Ford.

A SCHUNK pneumatic zero-point fixturing system presents the part to the spindle for the second operation in a time that rivals the speed of an automatic pallet changer. A probe double-checks the datum and that the bores machined in the first operation are the correct size. Face mills complete the rough and finish machining on the front of the pump body. The savings offered by this method of production sees all 50 to 60 bodies completed in one week rather than four.

Metaltech's managing director Doug Murphy comments: "We sent drawings to Whitehouse and they came back with setup and cycle times on the Spinner that looked really good, which was largely down to producing the bores by circular interpolation milling instead of single-point turning on a separate lathe.

"We were worried that it would be difficult to hold the required 20-microns diameter tolerance using this method. However, our fears were allayed by a set of three cutting trials the supplier carried out in its Kenilworth showroom. We checked the bores on our CMM for size, ovality and taper and they were within microns."

Technical director Mick Bignell adds: "Another concern we had was that the new method of roughing and finishing the back face completely before turning the part over to machine the front face and outside would put stress into the casting, causing distortion and movement of the datums. This also proved to be unfounded.

"We had to look carefully at the surface finish of the internals and bores, as these rotary lobe pumps are used in the food industry and any roughness could cause hygiene problems. External finish is also important to our customer, as the polished appearance is a sales advantage. The interpolation milling cycles established by Whitehouse have proved to be equal to these requirements and produce a finish equivalent to single-point turning."

Savings in tooling costs result from the new production method. The first thing to note is that on the HMCs, which use large indexable-insert cutters for roughing, the 60-station tool magazines are not big enough to accommodate all cutters needed for every pump variant. On the Spinner, with the new process allowing commonality of tooling, the 32 pockets are sufficient to machine the complete range.

Using a waveform rough milling strategy with the 16 mm diameter cutter at high speeds and feeds, typically 2,700 rpm and 2,400 mm/min, rapid metal removal rates are achieved without unduly heating and stressing the part, helping to maintain accuracy. It is largely this lighter machining that allows the BT40 vertical-spindle machine to attain the same level of precision as a 50-taper HMC when cutting tough stainless steel.

Tool life is very good, according to Mick Bignell. He says that one 16 mm end mill can rough 22 pump bodies, while a finishing end mill had completed 50 parts and was half way through the next batch at the time of interview. A further benefit of these £120 solid

carbide cutters is that two or three regrinds are possible at a cost of £25 per time. Overall, the lower cost of tooling represents a monetary saving that he describes as "immense".

A further economy derives from reduced power consumption. The Spinner draws between 10 and 20 amps whereas an HMC pulls 30 to 40 amps. Doug Murphy estimates that overall electricity usage will fall by two-thirds using the new pump body manufacturing process.

He concludes: "As demand for these pumps is continually rising, finding more efficient ways of manufacture is imperative. The reduction in setup time from as much as 15 hours to one is a big game-changer with the Spinner, as is the elimination of work-in-progress.

"The process has lowered the economical batch size and is helping not only to increase flexibility of production but also to reduce the cost. Also, by handling the parts fewer times, there is less risk of scrap. The customer also benefits, as they are able to reduce stocks levels.

"The ability of Whitehouse to turnkey this installation successfully has given us a path to expansion that was difficult to see before. We were out of space and out of power here in Hailsham and the high cost of relocation was not an option.

"The Spinner U-620, requiring half the floor space of an HMC and one-third of the power yet delivering the same quality of parts four times faster, has been a sea change for us."



Doug Murphy (left), managing director of Metaltech Precision Engineers, with technical director Mick Bignell

**Whitehouse Machine Tools Ltd Tel: 01926 852725**  
**Email: timw@wmtcnc.com www.wmtcnc.com**

## The NEW standard in 5-Axis machining

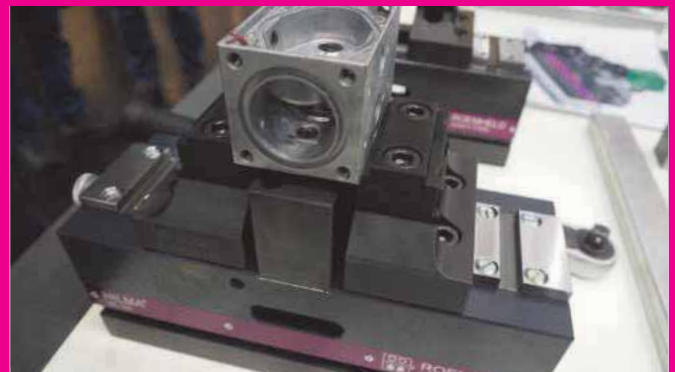

### No need for special tooling or pre-stamping

- Compact design for collision free tool paths
- High stability and precision – no need for pre-stamping
- Excellent accessibility
- Use with short, standard tooling



**ROEMHELD**  
 HILMA ■ STARK

Find out more at  
[www.roemheld.co.uk](http://www.roemheld.co.uk)  
 or call 01462 459052

Roemheld workholding. Driving Innovation through Manufacturing

# The year of innovation for Colchester

Colchester's successful and exciting 2019 included a move to its new European Technology Centre, the result of a two-year strategic review.

The new European Technology Centre is home to a purpose-built showroom, exhibiting the full range of Colchester machines, all available for customer demonstrations and applications training. Colchester's service, technical support, workholding and spare parts offering are also based at this site, which has received outstanding feedback at launch events and open houses from customers from around the globe.

Innovation has been a primary focus of the business, using the years of experience and knowledge gained in industry to develop new machines and a refreshed approach to service and support to meet the changing landscape and unique needs of a wide and varied customer base.

These latest developments have been branded the five innovations and were intended to be launched at MACH 2020.

However, the exhibition postponement has not deterred Colchester from bringing these innovations to market, launches will continue via online media platforms and when safe to do customers and stakeholders will be invited to the facility where physical demonstrations, live Q&A sessions will be provided alongside the opportunity to view the wider portfolio and facility.

The five innovations are made up of the following products and services:

### The Manual Machine Plus

This represents the new era in manual turning, created to bridge the skills gap in industry by eliminating time consuming mechanical setups. Designed and developed by Colchester, this ultimate centre lathe comes with inbuilt machine cycles, easy to use touchscreen operator interface ideal for one-offs and small batch production.

### Permanent laser marking systems

Working with sister company TYKMA ElectroX, Colchester now offers a wide range of market-leading industrial laser engraving machines ideal for product identification, providing the perfect marking solution for any application, material,



surface and composition. Bespoke custom builds to suit a unique application are also available from highly experienced application engineers.

### The next generation Alpha

The industry renowned Alpha CNC combination lathe has now progressed to generation 6. The Alpha comes complete with the latest generation control system from FANUC 0i-TF Plus, large working envelope, manual guide-i conversational programming system and the industry renowned Alpha operating system. The unique Alpha operator interface provides the user with maximum flexibility and versatility through the simple to use touch screen interface. Available with fully interpolating C-axis control and driven tools, the Alpha range is ideal for volume operations to one-off batch production.

### Automation

Working with partner Hydrafeed, Colchester now offer integrated solutions to streamline the machining process. Answering increased demand and shorter lead times, reduced numbers of CNC operators, automation reduces lead times, costs and increases operating efficiency. The automated robot cell can combine CNC



machines right through to permanent laser marking systems.

Design and engineering capabilities

The Colchester name has been trusted in industry for over 100 years, the knowledge and experience gained throughout this time is reflected in the longevity and build quality of Colchester, Harrison and Clausing machine tools. The experienced team of engineers use the latest 3D computer modelling software to collaborate with end users and develop innovative solutions across our machine tool and laser products.

Exclusive videos and previews of the innovations can be found on the Colchester website and social media channels. Alternatively, contact:

**Colchester Machine Tool Solutions**

**Tel: 01924 415000**

**Email: [info@colchester.co.uk](mailto:info@colchester.co.uk)**

**[www.colchester.co.uk](http://www.colchester.co.uk)**

## New machine range from Schaublin

Schaublin Machines SA has made a successful launch of its new 632-Y turning centre. The proud successor to the famous Schaublin 110 CNC with its minimal footprint of 2.4 sq m, the 632-Y is the result of Schaublin's unique expertise in the field of high precision lathes.

The new machine has been developed equally for production machining and small batch runs, as it combines flexibility with renowned Schaublin Machines precision and quality. The new 632-Y machine that was presented at a recent Open House exhibition is part of a modular range that includes several models with between three and five linear axes to suit the exacting needs of the end-user.

The range enables Schaublin Machines to present a machining solution dedicated to production environments as well as small batch or prototype machining. The 632-Y is the ideal partner for any company targeting high precision, repeatability and reliability. Schaublin Machines delivers all of this in a very compact and rigid turning centre with a

maximum turning diameter of 270 mm and a bar capacity of 32 mm diameter.

The 632-Y machine is a mill/turn centre that can work with bars or hard billets up to 65HRC with the option for integrated FANUC robot loading. Twin spindles and a motorised main turret with 12 x 12 tooling positions offer the user the possibility of driven tooling.

It is possible to work on both sides of the part simultaneously with OI-TF Plus Fanuc CNC with dual channels. The tooling options in counter-operation are a simple gang tool system or a 12 station Sauter VDI 16 turret with six positions driven. The main and counter-spindle are identical and this simplifies the transition between front and back-end work.

The turret has been designed to be as compact as possible to improve the mounting of live tooling that can operate at up to 12,000 rpm on every position. Working in a compact envelope with a high number of tooling demands exceptional chip removal. It is here that the 632-Y



enables cutting fluid to be directed precisely to the cutting edge at a pressure level up to an optional 100 bar. This efficiently evacuates swarf from the work envelope and also prolongs tool life.

The new 632-Y turning centre can also be programmed offline which incorporates an anti-collision system that enables the turret to work in close proximity, giving the operator confidence when working at high feed and speed rates.

**Schaublin Machine Tools Ltd**

**Tel: 01264 811602**

**Email: [info@schaublinmachines.co.uk](mailto:info@schaublinmachines.co.uk)**

**[www.schaublinmachines.co.uk](http://www.schaublinmachines.co.uk)**

## KUKA

Rotary friction welding solutions  
\_efficient and sustainable material bonds

KUKA UK's AWS (advanced welding solutions) sub-contract facilities located in Halesowen, West Midlands provide a full range of friction welding and support services for those customers and applications that cannot justify the capital investment but, whom still want to benefit from the process to grow their businesses. Not only can KUKA AWS offer rotary friction welding on a subcontract basis, consultation, pre and post weld processing inclusive of specialist, induction heat treatment and, metallurgical investigation and analysis via the fully kitted onsite laboratory is also available.

To discuss your subcontract friction welding requirements, please contact us at [sales@kuka-systems.co.uk](mailto:sales@kuka-systems.co.uk) or call us on 0121 585 0888

[www.kuka.com](http://www.kuka.com)

Thompson friction welding machines. Built by KUKA in the Black Country, UK.



# Hurco introduces new driven tool lathes

A new range of CNC turning centres with live tooling in the turret has been introduced by High-Wycombe based Hurco Europe Ltd. The three models, the TM8Mi XP, TM10Mi XP and TM12Mi XP, cover the popular 8-, 10- and 12-inch chuck sizes required by most manufacturers. Managing director David Waghorn explains the inception of the machines and where they fit into the company's product programme:



"Hurco previously sold a range of driven tool lathe models designated TMM, but their performance was limited as they were not controlled by the proprietary Max5 control that has proved so popular on the company's machining centres due to features such as concurrent programming and recovery restart.

"The new lathe control system, an in-house development by Hurco's software

engineers, was first introduced on the XP-series of 2-axis lathes in early 2018. The all-digital control platform was delivered alongside improvements to the design of the machine including a smaller footprint, roller guideways in the linear axes, a larger spindle bore and enhanced rigid tapping. The mechanical design has proven to be solid, accurate and reliable.

"A primary reason for developing the TM Mi XP range, in addition to adding the superior features of the Max5 control, was to ensure that driven tool milling is smooth and accurate. The machines include a servo-controlled C-axis and the capability to deploy driven tools at all turret positions, allowing milling and off-centre drilling to be performed in addition to normal turning operations."

Two machines are currently in the UK, a demonstration machine at Hurco and another on trial at a customer's factory. The first machines available for sale will arrive late June 2020. They will be the new 8-inch chuck models which, compared with the former TMM lathes, offer higher spindle power at 22.6 kW, a spindle bore increased from 62 to 79 mm, a draw tube diameter of 64.5 mm, up from 52 mm, and faster rapids at 30 m/min rather than 24 m/min. Coolant capacity has also increased.

The new CNC system uses a multi-core CPU that allows high resolution graphics on the screen, comparable with those on Hurco's machining centre control. Patented Ultimotion dynamic variable look-ahead software is standard, ensuring that machine motions are responsive, smooth and accurate, improving surface finish, tool life and cycle times.

Additional features of the control are: Concurrent Programming, Check for Errors, Compute Estimated Run Time, Recovery Restart in NC and Conversational, Linear Broaching, and Spindle Harmonic Control. There are plans to add features such as Tool and Material library in later releases.

Prices of the new lathes are the same as those of their former TMM equivalents. Hurco believes they will particularly appeal to manufacturers programming small volumes and one-offs directly at the control. However, the additional power and faster rapids should also make the products more appealing to those planning longer production runs.

The TM Mi XP range is part of a larger project within Hurco that will see the addition of further driven tool lathe models over the coming years. The addition of Y-axis and sub-spindle versions is anticipated for mid-2021.

Hurco has been leading the industry in CNC machine tool technology for 45 years with 80 patents to its name. It understands the importance of agility, adaptability, and profitability when it comes to running a business. That's why it makes reliable CNC machine tools with the most versatile control in the industry by providing both NC and conversational programming.

Hurco's CNC machine control, powered by WinMax software, is the key to making job shops more profitable because it is designed to make small batch/high mix production efficient by reducing setup time and programming. It is crucial for subcontractors to be able to program and set up multiple jobs per day on many occasions and this is where Hurco's machine control comes in.

**Hurco Europe Ltd**  
**Tel: 01494 442222**  
**Email: sales@hurco.co.uk**  
**www.hurco.co.uk**



Hurco has introduced a new range of three driven tool lathes with roller guideways, larger spindle bore and an upgraded Max5 control

## Hanwha sliding heads are breathing life into Ventilator Challenge

With the sudden ramp-up of the 'Ventilator Challenge UK' project to battle the Coronavirus (COVID-19) pandemic, Dugard Machine Tools has witnessed an unprecedented surge in enquiries and sales with its Hanwha range of sliding head turning centres.



As manufacturers up and down the country switch production output to machining small turned components for the Ventilator Challenge UK, the attributes of the Hanwha range are genuinely coming to the fore. The Hanwha XE Series is the latest generation in a well-established and successful line of rigid, productive, robust and extremely flexible turning centres. Enjoying particular success during this challenging period is the Hanwha XE35.

The compact heavy-duty machine is the largest in the XE Series with the facility to turn bars up to 35 mm diameter within its compact 2.3 by 1.2 by 1.7 m footprint. The rigid 2,750 kg machine is the perfect platform for machining hard materials and undertaking high-volume material removal. This is demonstrated by the vibration dampening heavy cast construction and the strong and rigid tool post that all combine to create a platform for unsurpassed surface finishes and enhanced tool life.

The remarkably capable and flexible Hanwha XE35 has a powerful 2.2/5 kW main spindle motor and a 1.5/2.2 kW sub-spindle motor, both achieving a maximum spindle speed of 6,500 rpm. The high-torque spindle motors are matched by the powerful and intuitive Hanwha software, the FANUC-0i CNC Control and the gear type modular live tooling configuration.

The tooling configuration combines power, rigidity and flexibility with 18 tooling positions that provide simultaneous front and rear spindle machining through a platen of five fixed tools and four driven tools in the X1-axis with another four driven tools on the Z2-axis plane, one on the Z1-axis that is accompanied by an additional four tool stations for boring, drilling and the machining of other internal features. All live tooling positions offer a high spindle speed of 6,000 rpm with a 1kW spindle motor. The modular gear type live tooling configuration is an innovative design that generates exceptional torque levels for heavy drilling and milling cycles.

**C Dugard Ltd Tel: 01273 732286**  
**Email: sales@dugard.com. www.dugard.com**



## THE AJAX SUPER MINI LATHE



### Ajax AJAT210 SUPER MINI/CNC LATHE SIEMENS CNC Control

210 mm Swing x 400 mm  
 100 mm 3 jaw chuck, 240V 1ph  
 (Fits in a 13 amp plug socket)  
 4 Station Automatic Toolpost, Coolant,  
 On wheels, will go through a normal door

**£10,950.00**  
+ VAT

See it cutting on our website

**Ajax Machine Tools International**  
**Tel: +44 (0)1590 676000**  
**sales@ajax-mach.co.uk**  
**www.ajax-mach.co.uk**

# Rotary table range expanded

Early last year, Japanese manufacturer Kitagawa introduced the first in a new range of compact, general purpose rotary tables, the MK-series, for adding a rigid fourth CNC axis to a 3-axis vertical machining centre. One year later, the MK200 has been joined by a second model, the MK250, with significantly uprated performance. Availability in Britain and Ireland is through sole sales agent 1st Machine Tool Accessories, Salisbury.

The most notable improvement on the MK250 is the 1,000 Nm, pneumatically actuated clamping torque, making it more than four-fifths stronger than the first model. As with all Kitagawa tables, this torque is determined by the point at which the force on the worm wheel causes it to displace by 30 microns. In contrast, some manufacturers quote the slipping torque as a maximum, which can cause inaccuracy or even failure.

If a Kitagawa TSR181A tail spindle with integral clamp, also available through 1st MTA, is added for securing a component or tooling column horizontally between centres, clamping torque increases to 1,600 Nm. The result is even faster, heavier duty, more productive machining. As the table has a small footprint, loss of bed area and working volume in a machining centre is minimised.

Kitagawa has both stronger and more

compact rotary tables of similar capacity in its product ranges, for example the GT250 and CK250 respectively, but Kitagawa asserts that the MK250 meets 90 percent of all customer requirements. The unit on its own can support a load of 250 kg horizontally, while it may alternatively be used to hold a component or column weighing up to 125 kg in the vertical orientation. Maximum positioning speed is 33.3 rpm.

The type of the faceplate is specified by the customer, either with T-slots or pre-drilled holes. The advantage is that a chuck, trunnion or other workholding device can be mounted directly onto the rotary table, reducing the distance from the spindle bearing. Such compact assembly lessens the load on the bearing, increasing rigidity and longevity. Cutting torque is 480 Nm and the spindle through-hole diameter is 70 mm.

The table design minimises accumulation of chips around the base, reducing cleaning time and ensuring the absence of interference to the workholding arrangement, an important consideration in automated production cells.

Compact, built-in, 7 MPa rotary joints may be selected from 4-, 5- and (6+1)-port types, the latter having a 12.5 mm diameter, multi-purpose hole through the centre for



The new Kitagawa MK250 rotary table from 1st MTA

additional hydraulic or pneumatic services to actuate workholding. The hole can also be used as a duct for cables feeding signals back from fixture sensors confirming correct workpiece seating, enabling the design of the workholding configuration to be improved and its capabilities enhanced.

1st MTA will alternatively provide a high pressure 25 MPa, 4-port or 6-port rotary joint instead of the standard 7 MPa variety, allowing a further reduction in fixtures sizes as well as improved clamping speeds.

For more information, visit [www.1mta.com/product/mk-series](http://www.1mta.com/product/mk-series).

Established to offer a comprehensive selection of top-quality products at competitive prices, 1st MTA is your first stop for high quality workholding products with world beating technical support and assistance.

Specialist engineers carry out site visits, advise on the most appropriate workholding methods for individual applications and if possible, offer demonstration of the products' performance.

A dedicated team of technical engineers are on hand answer your questions, provide solutions and offer outstanding service.

A constantly expanding and updated product range offers you the best possible choice, including: Kitagawa, IEMCA, Chick, Abbott, Darex, Brighetti, OK-Vise, Technomagnete, Walmag, Eclipse, V-Tech, TdeG, Effecto, Wogaard, BEST, Engineering Data.

**1st Machine Tool Accessories Ltd**  
**Tel: 01725 512517**  
**Email: [enquiries@1mta.com](mailto:enquiries@1mta.com)**  
**[www.1mta.com](http://www.1mta.com)**



The MK Series in production



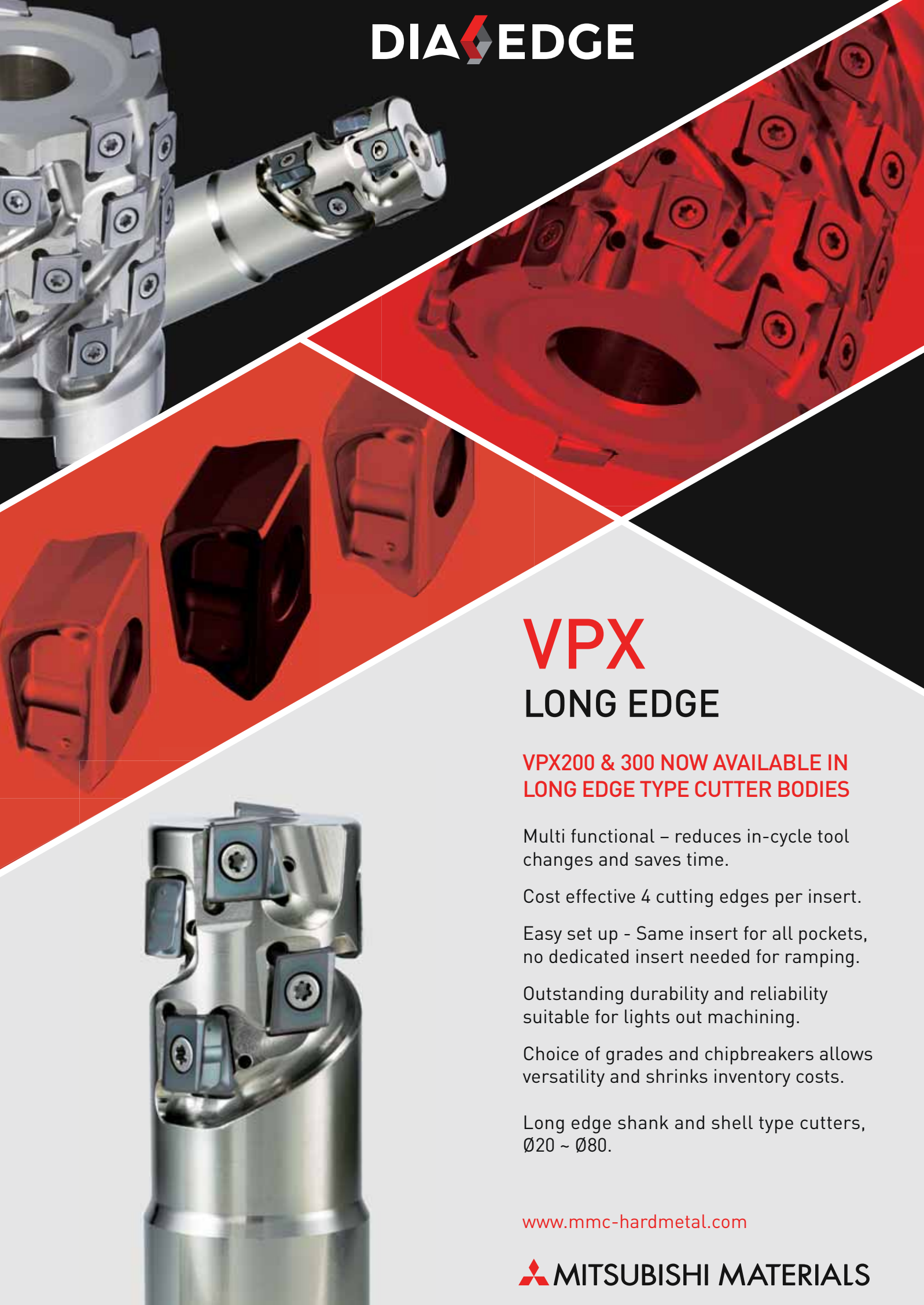

## VPX LONG EDGE

**VPX200 & 300 NOW AVAILABLE IN  
LONG EDGE TYPE CUTTER BODIES**

Multi functional – reduces in-cycle tool changes and saves time.

Cost effective 4 cutting edges per insert.

Easy set up - Same insert for all pockets, no dedicated insert needed for ramping.

Outstanding durability and reliability suitable for lights out machining.

Choice of grades and chipbreakers allows versatility and shrinks inventory costs.

Long edge shank and shell type cutters,  $\text{Ø}20 \sim \text{Ø}80$ .

[www.mmc-hardmetal.com](http://www.mmc-hardmetal.com)

# New long edge type cutters for the VPX 200/300 Series

The VPX200 & 300 range of tangential, indexable insert milling cutters from Mitsubishi Materials has been expanded to include new, long edge types. These long edge types expand the application area to include deeper shoulder and pocket machining and complement the recently launched sharp geometry L-breaker inserts for the VPX200 type.

### Multi-functional

The VPX series have the ability to be used over an extremely wide range of milling functions, ranging from standard shoulder milling through to ramping and pocketing. This multi-functionality was a key factor in the original design parameters, together with the knowledge that today's machinists require both high performance and optimum usability to reduce cutting tool inventories.



MP7130 for stainless steels

### Tangential double-sided inserts

The insert geometry provides the required toughness together with the ability of multi-functionality. Importantly, the inserts are double sided and therefore provide the essential element of economy. Additionally, when using the standard-length cutters, the convex curved, precision cutting edge produces highly accurate vertical wall surfaces with a maximum of only 8 µm cusp height between each machining mark.

### Insert grades and coatings

Eight different types, including the latest MP6100, MP7100 and MP9100 series of grades are offered to cover machining of materials from carbon, stainless and hardened steels through to cast iron and difficult-to-cut materials.

The VPX 200 and larger 300 series cutters are available in two different sizes to accommodate both large and smaller



VPX200 long edge

machines. The 200 series has 09 size inserts, whilst the 300 has larger 12 size inserts and both series are available in shank, screw-in and arbor types, ranging from Ø16 - Ø80.

The new long edge versions are available in the smaller VPX200 range as a shell type from Ø32-Ø50, a standard shank type from Ø20-Ø40 and in a Weldon shank type from Ø20-Ø32. Also new in the larger VPX300 range are shell types from Ø40-Ø80 and as a standard shank type in Ø40.

**MMC Hartmetall GmbH**  
**Tel: 0049 2159 918921**  
**Email: markt@mmchg.de**  
**www.mmchg.de**



MP6130 for steels



For more information:  
[cutting.tools/en/wtx-hfds](http://cutting.tools/en/wtx-hfds)

## Four-edged Powerhouse

The WTX HFDS is the  
Number 1 in solid carbide drilling

TEAM CUTTING TOOLS

CERATIZIT KOMET WZT klenk

## Guhring stocks standards and manufactures specials to support COVID-19 Challenge

Social media is currently 'alight' with UK engineers doing the country proud in meeting the 'Ventilator Challenge UK' demand to support the battle against the Coronavirus (COVID-19). Likewise, the supply chain is flying the flag for UK manufacturing with its response to keeping this critical infrastructure in motion.

As part of this supply chain, Guhring UK has stepped up to the plate with the critical supply of cutting tools in a way that is beyond compare. As a UK manufacturer with a factory floor space of over 60,000 sq ft, Guhring UK is holding in excess of £5m of standard cutting tool stock items. This stock is being directed to both F1, aerospace and medical OEM's involved in the 'Ventilator Challenge UK' as well as the subcontract supply chain. In fact, with the impact of the pandemic on imports and the wider supply chain, Guhring UK is even supplying its products to recognised cutting tool manufacturers and competitors that cannot meet the urgent demands of their customer base.



Despite Guhring UK holding a plentiful stock of thousands of standard cutting tool items for next day delivery, it is the UK manufacture and coating of special tools that are really 'saving the bacon' for pockets of the supply chain at such a critical time.

One customer, Bellurgan Precision Engineering Ltd, based in Ireland, urgently required a three step special drill for production of ventilator components and Guhring stepped up to the mark delivering within 48 hours. Within that 48-hour time frame, Guhring UK had liaised with Bellurgan and designed and created a tool drawing that was subsequently approved and then the race was on. The Guhring UK team immediately manufactured 16 identical tools at its Birmingham headquarters and coated all tools in-house with its Signum coating technology before delivery to Bellurgan Precision in Dundalk, County Louth, Ireland.

Guhring UK is one of the only UK cutting tool manufacturers that can achieve this, as its design, development, manufacturing, coating and delivery departments are all working to continue 'service as normal' even during a pandemic. So, if you are taking up your role as part of this critical infrastructure, Guhring UK is here to help you face the challenges that demand new and innovative cutting tool solutions. At times like these, you can put your confidence in a UK manufacturer like Guhring UK to service all your cutting tool requirements.

**Guhring Ltd**  
**Tel: 0121 749 5544**  
**Email: info@guhring.co.uk**  
**www.guhring.co.uk**

**BIG KAISER**  
**THE KEY TO YOUR SUCCESS**

**www.bigkaiser.com**  
**A Member of the BIG DAISHOWA Group**



Sole distributor for the UK and Ireland  
 www.itc-ltd.co.uk, Tel: 01827 304500



## Automatic boring available from ITC

BIG KAISER, a global leader in premium high-precision tooling systems and solutions for the metalworking industries, has now introduced the latest version of its EWA fine boring tool. Available in the UK from Industrial Tooling Corporation (ITC), the new intelligent and fully automatic fine boring tool received its exhibition premiere at the EMO 2019 show in Hannover.

Being a fully automatic fine boring tool, the EWA does not require human intervention. It achieves fast, accurate boring and this is because the process does not need to be stopped to make measurements or manual adjustments to the fine boring tool. As well as saving time, this instils confidence in the operator, and it minimises costly scrap that can result from manual adjustment errors.

The new EWA features a powerful motor for robust and reliability operation and it is sealed against dirt and water in accordance with IP69 regulation. The clamping system provides additional stability and repeatability to deliver consistently high levels of reliability and precision at cutting speeds above 200 m/min.

The EWA can be used with BIG KAISER's extensive standard range of accessories, making it easy to add to an existing system. To maximise flexibility, it offers an adjustment range of 22 mm, which is



substantially larger than similar solutions available in the market. Furthermore, the system has an integrated accelerometer that measures vibration during the cutting process and in the event of excessive vibrations, the EWA alerts the machine tool to automatically adjust its cutting parameters.

The new EWA initially comes in two versions. The EWA peripheric covers diameters from 68 mm to 90 mm and the EWA centric, which will incorporate a central

boring bar with internal coolant for smaller diameters. Other models for different adjustment ranges are currently in the design phase and destined to be introduced in the near future.

The demonstration at the EMO exhibition was undertaken on a FANUC CNC machine, whereby the entire boring cycle was performed automatically. This included the initial bore machining, subsequent measuring and then the adjustment process to complete the final precision bore.

The EWA features wireless connectivity to BIG KAISER's user-friendly smartphone and tablet app for easier tool monitoring and configuration. It can also automatically communicate with a pre-setter, so diameter measurements can be transferred without operator intervention.



**Industrial Tooling Corporation Ltd**  
Tel: 01827 304500  
Email: sales@itc-ltd.co.uk  
www.itc-ltd.co.uk

**GUHRING**  
The Tool Company

**RT100XF**  
NEW. EXTREME. POWERFUL.

High performance drill with exceptional performance and quality - guaranteed outstanding results for your processes.

T: 0121 749 5544  
e: info@guhring.co.uk  
www.guhring.co.uk

# Kyocera expands its MFH high-feed milling cutter series

Kyocera has added the new PR015S MEGACOAT HARD insert grade for stable machining of hardened materials to its MFH high feed cutter series. In combination with the likewise new GH Chipbreaker, it is ideal for a wide range of applications and especially for difficult milling operations. Both extensions are integrated into the MFH Harrier and MFH Mini Series.

### Convex cutting edge design for low cutting forces

The GH Chipbreaker has a convex and very robust cutting-edge design, so that cutting forces are reduced when entering the workpiece. The high-feed tool also has excellent breaking resistance. Along with the PR015S insert grade, the new chipbreaker is suitable for stable machining of hardened material.

The PR015S is characterised by its high hardness and extremely heat-resistant PVD coating MEGACOAT HARD, which improves wear resistance. The combination of the GH Chipbreaker and the PR015S also reduces heat cracks and increases the



breaking strength of the insert. Different geometries offer the right solution for the high precision technology industry with a maximum cutting depth of up to 5 mm.

### Kyocera responds to high market demand with MFH expansion

Since its introduction in 2014, Kyocera has continuously expanded its range of state-of-the-art MFH cutting tools. This range now includes diameters from 8 mm to 160 mm. All inserts in the series feature a convex, spiral edge design, making them



ideal for various shoulder, ramp, slot, plunge, helix and face milling applications. The MFH was Kyocera's first high-feed milling tool and completes the comprehensive line of cutting tools to meet various manufacturing challenges.

**Kyocera Fineceramics Ltd**  
**Tel: 0049 2131 1637188**  
**Email: daniela.faust@kyocera.de**  
**www.kyocera.de**

Designed and Manufactured in the UK by Micron Workholding  
 MicroLoc is a registered trademark of Micron Workholding Ltd

- The all **NEW** hydraulic system reduces operator fatigue
- Increases productivity
- All the benefits of the manual MicroLoc System



**Secure clamping on just 2mm**

Helping you hold onto your **PROFIT!!**



Visit us at MACH: Stand 19-20

Micron Workholding Ltd

SALES 01480 861321  
 www.microloc.com  
 sales@microloc.com

Made from sugarcane.

rose plastic®  
 innovations in plastic packaging

rose plastic UK Ltd. Phone +44 1709 7217 94 · info@rose-plastic.co.uk · www.rose-plastic.co.uk

# Simplified high accuracy measurement

Image Dimension Measurement System takes complex component readings quickly, easily and accurately



Aerotron Avotec is a Scottish maintenance and repair organisation in the aviation industry specialising in the repair and overhaul of a variety of rotary and fixed wing aircraft components for civil and military customers. The company is renowned for its technical excellence and meticulous approach to repairs as well as offering one of the lowest warranty rates in the aerospace industry.

Due to the demanding nature of its work, Aerotron Avotec has to work with a wide range of complex parts that can include tiny bearings as well as shafts, gears, brake components, wheels and large outer casings for aircraft undercarriages. Engineers at the company are tasked with inspecting parts to extremely tight tolerances and this can often mean taking key measurements from difficult to access areas. At the same time, readings taken can be of a nature that prevents them from being measured with traditional measurement equipment.

Checking these parts to meet the stringent demands of customers would ordinarily require Aerotron Avotec to



acquire expensive, specialist 'one-off' measurement tools. For example, a small gear shaft not only needs measurements taken of its external splines but also its internal spline and fixed central shaft. Pin

measurements need to be taken to measure gear wear while the bearing lands on the shaft also need to be checked for wear.

Normally, carrying out these checks requires three different traditional measurement tools: an external micrometre, a specialist micrometre with calliper jaws to access the central shaft, which is partially enclosed by the internal gear and a specialist bore gauge with an open centre to allow the internal gear surface (which is obstructed by the internal shaft) to be measured.

After scanning the market for the most suitable solutions to its problems, Aerotron Avotec invested in the IM-7500 optical imaging measurement system from Keyence which has enabled measurements such as those mentioned to be acquired using just the one instrument and in a fraction of the time that it used to take.

At the same time, using the Keyence system has increased significantly the accuracy of measurements taken by Aerotron Avotec, mainly through being able to reduce the amount of human interface involved when measuring the part and with the associated tooling. Once the information gathered is programmed into the memory of the machine, parts of the same specification can be measured quickly and simply with one or two button clicks. This greatly reduces the number of man-hours that would traditionally be spent on such a task.

The IM-7500 Image Dimension Measurement System is designed to be easy to use, with no measurement expertise required, and to measure up to 99 dimensions in just a few seconds, with a measurement volume of up to 300 mm x 200 mm.

Featuring automatic recognition of component position and orientation, the



system eliminates positioning errors as well as focus errors and skill level errors. Also, every type of measurement can be carried out on many different parts, whether machined, turned, injection moulded or stamped, without having to switch programs. As well as offering consistency in all its readings regardless of the operator, the IM-7500 automatically records all captured data and produces a range of comprehensive inspection reports which can be read on a PC or hand-held device running standard software.

One of the main benefits that the Keyence system has brought to Aerotron Avotec, then, is to simplify the company's highly complex measurement requirements. The IM-7500 has not only minimised the potential for human error when taking measurements but has also reduced the number of tools that are required for the task. In some instances, the Keyence equipment has enabled series of measurements that would have needed a few days to acquire to be completed in a couple of hours or even less. The IM-7500 has also allowed measurements to be taken that otherwise would have required the purchase of bespoke tooling.

**Keyence Ltd**  
**Tel: 01908 696900**  
**Email: [ukinfo@keyence.co.uk](mailto:ukinfo@keyence.co.uk)**  
**[www.keyence.co.uk/aerotronavotec](http://www.keyence.co.uk/aerotronavotec)**



## Third Dimension launches GapGun upgrade

Third Dimension has taken the industry standard to a new level with the GapGun Pro2 and T series sensor heads. Designed for the increasing needs of automotive metrology and quality control professionals, a dedicated team of engineers have spent three years to build cutting-edge technology into the 25+ year established GapGun. The goal was to realise Third Dimension's ambition to deliver the ultimate non-contact, precision measurement tool.

Reliable, intuitive and accurate, GapGun Pro2 retains the same favoured ergonomics for operators and continues to deliver fast measurements and repeatable results. GapGun Pro2 is a simple upgrade option for existing users.

The noticeable change comes with a new, 'T60' sensor head family. The T60 now delivers 3.5x better pixel resolution which delivers enhanced accuracy. Still fast, the GapGun Pro2 has a measurement cycle of just one second but comes in a smaller and more robust casing than its predecessor. The new sensor heads have several optical improvements that enable them to deliver

sharper, more reliable data across a broad range of applications.

Chih Jen Lo, chief applications engineer at Supertooling in Hong Kong comments: "For those used to working with GapGun, the new product provides some really pleasing improvements. Existing users will find it easier to use and enjoy the added simplicity when checking vehicle quality."

Understanding the inline and offline automotive environments has been the key to Third Dimension's success. Available with a red or violet laser, T60 sensor heads can measure all common automotive surfaces, including light clusters and gaps with chrome.

In addition to this, T60 sensor heads have been completely re-engineered to further enhance their robustness. Improved mounting of optical elements, reduction of internal cabling and improved ingress protection mean they are reliable and remain in calibration when exposed to the rigours of inline production quality checks. T60 sensor heads are MIL-STD-810g drop tested and IP rated so metrology lab



**GAPGUN<sup>®</sup>PRO2**

precision really can be brought to the production line.

As the only company able to deliver calibrations on optical triangulation sensors in an ISO 17025 certified lab, traceability on the GapGun Pro2 is industry leading and delivers a complete audit trail for quality control professionals.

Request a demo by contacting [sales@third.com](mailto:sales@third.com) or contact:

**Third Dimension Ltd**  
**Tel: 0333 3443 000 ext: 511**  
**Email: emily.brooks@third.com**  
**www.third.com**

## ZEISS offers cutting edge measurement technology

ZEISS can supply an extensive range of cutting-edge measurement technology, including the new ZEISS PRISMO Verity, the ZEISS CONTURA and, the first in the UK, the ZEISS SRE MAX.

Delivering results with an uncertainty as low as 0.7+L/400 µm is made possible by using ZERODUR<sup>®</sup> scales and advanced CAA correction. The ZEISS PRISMO Verity offers gauge room precision whilst operating in measuring rooms with temperature controls that meet the German VDI/VDE 2627 "Class 3" standard and air-conditioned rooms with temperatures maintained between 19° and 22°C and with the addition of improved form measurement values. PRISMO Verity is the best machine in its class.

With its modular construction the ZEISS SRE MAX is available in different sizes designed to suit customer requirements. The system features ADR (Automatic Defect Recognition) and real time image acquisition allowing for Radioscopic Inspection cycle times of only a few seconds. This class leading performance is paired with all ROI (Region Of Interest) NDT testing procedures

being regulated by international standards, for example ASTM, making the SRE Max perfect for both low and high-volume manufacturing requirements. In addition, to accommodate larger components the option of a 450 Kv source is available.

With safety being paramount, ZEISS SRE MAX complies with the strictest international regulations for fully shielded radiation devices. During the show customers will be able to review scanned data using a VR system, allowing customers the chance to walk through the results in a VR environment.

ZEISS can also provide the new CONTURA. The CONTURA represents a huge step forward for CMM's in this class. Features include: Multi-Application-Sensor-System enabling the use of all sensor types on the same platform; DLC (Diamond Like Carbon) coated guideways, new air bearing technology, fully integrated rotary table enabling true 4-axis scanning, previously only available on high end machines, glass ceramic scales allowing for HTG (High



Temperature Gradient) requirements; automated probe change rack capability enabling zero impact on measuring volume; new advanced scanning technology - all contributing towards a system that is now the absolute standard in its class.

Whether you are interested in scanning small intricate parts, automotive styling clays or vehicle interior parts, ZEISS has a solution for you.

**ZEISS**  
**Tel: 01223 401469**  
**Email: emma.baynes@zeiss.com**  
**www.zeiss.com**

# Mitutoyo helps the R&A to ensure fair play on the fairway

Currently celebrating the 40th anniversary of its establishment, Mitutoyo UK has earned an excellent reputation for the accuracy and quality of its products and the wide range of metrology and testing disciplines it covers. Within the fields of contour and surface roughness measurement, Mitutoyo services the needs of many hi-tech industries, such as the aerospace, automotive and medical sectors. In addition, the company provides non-engineering business, that have their own specific contour and surface roughness measuring demands, with an extensive range of contour and surface roughness instruments.

A recent Mitutoyo contour and surface roughness instrument installation demonstrates the diverse nature of the company's customer base and also helps to illustrate the rigorous conformance standards applied to golfing equipment.

Situated close to the home of golf near St Andrews, the R&A engages in and supports activities undertaken for the benefit of the sport of golf. Together with the USGA, the R&A governs the sport of golf worldwide, operating in separate jurisdictions while sharing a commitment to a single code for the Rules of Golf, Rules of Amateur Status and Equipment Standards.

The R&A's Equipment Standards role can be divided into three main areas: evaluating submissions of new equipment for conformance to the Rules of Golf, conducting fundamental research into the science of golf and constantly reviewing the equipment rules to ensure that they remain relevant to today's equipment and that they continue to ensure that skill remains the dominant determinant of success.

The rules and specifications related to



golf clubs are divided into five separate categories: club (general), shaft, grip, clubhead and club face. Having used a previous generation Mitutoyo Formtracer instrument for measuring the impact area markings on club faces for some years, the organisation recently took delivery of the newly launched, advanced Mitutoyo Formtracer Avant model. The Formtracer Avant is now being used to precisely measure the profiles, widths, depths, edge radii and the separation distances of the of the grooves located on golf club faces' impact areas, against the relevant specifications as detailed in the Equipment Rules. In addition, as the Formtracer Avant is a flexible hybrid instrument, it is also used to inspect the surface finish of club face's impact areas against the Equipment Rules.

"Each week, we receive 30-40 submissions of new equipment for evaluation against The Equipment Rules," explains assistant director - Research and Testing at The R&A, Andrew Johnson. "We use a wide range of precise testing procedures, depending on the product categories submitted for assessment, to ensure that manufacturers' submitted equipment does not exceed the set limits.

"Our previously purchased Mitutoyo Formtracer has proven to be reliable and has provided the levels of accuracy and ease of use that we needed. Replacing it with the new Avant model will help to ensure that we are able to keep-pace with the high-volumes of contour and surface roughness testing."

Mitutoyo Form Measuring Systems are available for efficiently assessing a range of complex shapes and to provide a wide range of accurate surface roughness readings.

The innovative Mitutoyo Formtracer

Avant series avoids the need to invest in two separate devices, as it can convert from a surface roughness measuring instrument into a contour measuring device and vice versa within seconds. The easy-to-operate, benchtop machines feature a motorised granite column and stand, plus a remote-control box that enables quick and accurate machine positioning. Fast, accurate CNC operation further aids efficient operation.



The flexible Formtracer Avant C-3000 series boasts a large vertical range, high resolution and a built-in drive unit inclination mechanism, allowing easy measurement of a large workpiece. Also, as an advanced hybrid instrument, it can deliver precise surface roughness and contour measuring results across a wide range of objects, including those with small features.

Complementing the Formtracer Avant's robust and accurate hardware, Mitutoyo's dedicated analysis software interprets and displays both contour and surface roughness measurement results in the quick and efficient manner that is required in busy testing facilities and quality control departments.

**Mituyoyo (UK) Ltd**

**Tel: 01264 353123**

**Email: philip.fisher@mitutoyo.co.uk**

**www.mitutoyo.co.uk**



## A machining boost for high value manufacturers

Blum-Novotest invests £150,000 in launch of new LC-Vision software

One of the global leaders in production metrology, Blum-Novotest has invested over £150,000 into bringing groundbreaking new software to market that will help firms get the most out of the LC50 DIGILOG laser measurement system.

Experts from the East Staffordshire-based business will be rolling out the innovation that visualises measurement results covering 3D ToolControl, SpindleControl and GrindControl.

This means users from automotive, aerospace, medical and renewables will know sooner about wears and defects on the tool cutting edges, visualisation of spindle wear to improve preventative maintenance and detailed representation of issues with the grinding wheel.

Managing director David Mold comments: "We launched the LC50 in 2018, the next generation of the laser and the latest addition to the hugely successful DIGILOG family.

"After listening to our customers, we are delighted to introduce LC-Vision, which will give machining firms the ability identify wear and defects in the cutting tools and grinding

wheels quicker, allowing them to compensate for them whilst still in the machine.

"By utilising a 'Best Fit' feature, tools can be modified so parts are machined much more accurately than before so every component coming off should be good. Scrapping or re-working should be a thing of the past with this software."

The plan will be to include the LC-Vision software on machines fitted with Blum-Novotest's DIGILOG LC50 laser measurement system free of charge.

Every application will be shown on the software, but only those purchased will be active, with customers able to purchase additional features as part of a licensing agreement. The company's expert engineers will be available to deliver full training so the client can get the most out of the software.

Future development will eventually cover the rest of the DIGILOG range, including probe, roughness gauge probe and the bore gauge system.

David Mold continues: "LC50 evaluates the analogue signal rather than the digital



one, meaning we can take thousands of measuring values of all cutting tool edges per second, resulting in highly dynamic measurement of tool parameters. In essence, this technology is 60 percent quicker than conventional in-machine measuring.

"Interest has been huge and we have retrofitted the technology on to a lot of machines. LC-Vision is a natural evolution of the solution and will give the customer even greater control.

**Blum-Novotest Ltd**  
**Tel: 01283 569691**  
**Email: info@blum-novotest.co.uk**  
**www.blum-novotest.com**

## A new type of contour measurement

With the new CMS 700i 3D contour measurement system, Leuze electronic is presenting a world's first for volume measurements: a complete solution for the fault-free storage of goods that can be autonomously commissioned and maintained by the customers via WebConfig. Figure 1: CMS 700i contour measurement system, application in e-commerce for packet measurement

With the CMS 700i, Leuze electronic is bringing a new 3D contour measurement system to market. Based on the CML 730i measuring light curtains, it can be adapted to specific customer requirements. The complete system includes all components, the switch cabinet, fastening elements and connection technology all under one part number. The CMS 700i meters the contour and position of passing objects regardless of their shape and surface structure. Even flat objects such as polybags can be precisely and economically detected without complicated camera installation.

The minimum dimensions for height, width and length are 5 x 50 x 50 mm<sup>3</sup>. The object information can, for example, be used to optimise the load on a pallet or to optimize the incoming goods. At the same time, deformations or protrusions of the object that might cause problems or downtime when warehousing automatically are reliably detected. The CMS 700i thereby increases the availability and cost effectiveness of the system.

With the intuitive WebConfig, commissioning and remote maintenance can be performed easily by the customer. Should a component need to be replaced, this can be accomplished efficiently with Plug & Play, without any specialist knowledge from supplier experts. This saves time and money. The Ethernet TCP/IP or PROFINET interface ensures speedy integration of the 3D contour measurement system. The system can collect peripheral data, e.g., from scales or bar code scanners, via an open Ethernet interface and pass it on

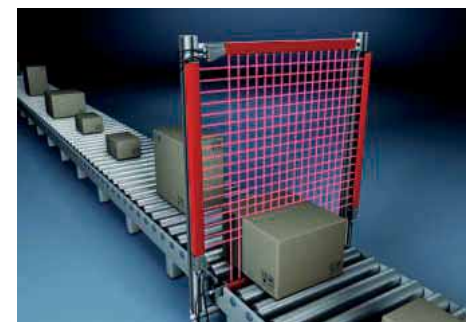

The CMS 700i contour measurement system application in e-commerce for packet measurement

with a time stamp. The CMS 700i can thereby be freely combined with additional functions and is suitable for both new and existing systems in the area of intralogistics.

**Leuze Electronic Ltd**  
**Tel: 01480 408 508**  
**Email: gary.hockin@leuze.co.uk**  
**www.leuze.co.uk**  
**www.smart-sensor-business.com**



# Collision prevention function can prevent over 80 percent of production downtime

Lantek, the leading multinational in the development and commercialisation of CAD/CAM/MES/ERP solutions and pioneer in the digital transformation of companies in the sheet metal industry, reveals the new features and improvements in the latest version of its software.

In total, there are over 100 improvements and updates across the whole range of solutions in the Lantek Global Release 2020. The most significant include collision prevention on the cutting machine and a new algorithm for destroying scrap metal efficiently on tube cutting machines. However, one aspect of this version that is very relevant at the moment is the possibility of using your software remotely.

### Lantek Expert: safety in cutting and automation

The update to Lantek Expert, the suite of programs for cutting and punching sheet metal, focusses on providing clients with functions that maximise the productivity and efficiency of their machines. In the new version of its accredited CAD/CAM 2D software, Lantek has added a total of 34 new features.

The main development is the capability of running an algorithm to prevent collisions during the cutting or punching process. This works by automatically adding fasteners (or micro-joints) to the holes or parts that, once they have been cut, could cause a collision between themselves and the cutting head.

Lantek has also improved the usability of all of the functions related to fasteners or micro-joints, focusing on two aspects: the improvement in precision of the final width of these elements and accurate simulation, in real-time, when they are added manually. For shapes that the user does not want to fasten into the sheet with micro-joints, Lantek offers the possibility of scrapping them using a new zig-zag technique ensuring that the waste material discharges safely.

Lantek Expert now includes functions to



help with production management in the workshop. Waste or leftover sheet material can be automatically marked on cutting machines so that it is easy to identify. The material can be marked with the company's identifier code as well as its measurements and weight.

### Lantek Flex3d optimises tube cutting to avoid collisions

The tube cutting market is growing exponentially thanks to the fact that new machinery manufacturers are beginning to develop this technology and that existing machinery is evolving with new devices and systems to improve efficiency and automate the cutting of tubes.

Evolving with the needs of the market, the new V40 version of Lantek Flex3d incorporates a new algorithm that allows you to destroy scrap generated from cutting holes in tubes. Without this new capability, hole cutting can cause numerous collisions with the machine head as well as possible damage when scrap falls onto supports. Furthermore, a new head management algorithm allows contours that have previously been cut to be avoided to minimize collisions and, machining time reduced by avoiding unnecessary raising and lowering of the head.

The combination of these two new features eliminating over 80 percent of current machine downtime caused by collision, is a highlight of this version of the software.

For new devices that automate the loading and unloading of parts, Lantek Flex3d V40 incorporates automated management of supports and unloading trays allowing the machine to work fully autonomously.

### Lantek Integra & MES

The new 2020 version of Lantek Integra incorporates significant improvements in its interface to adapt it to the current design standards in applications. The new graphics offers better use of space on the screen and an improved visual experience that includes changes to the colour palette, icons, font sizes and some navigation mechanisms. This results in greater efficiency in the users' daily tasks. In addition, the advanced visualisation dashboards of the commercial function, Customer Analytics has been enabled.

Meanwhile, Lantek MES Manager now has a new extension, MES Monitoring, which displays, graphically and in real-time, the sequence of operations on each work centre. It offers different Gantt display modes, as well as different mechanisms that allow you to visually search and skip through the operations according to different criteria. This version also enables the advanced manufacturing visualisation dashboards, Manufacturing Analytics.

### Lantek Systems Ltd

Tel: 01684 585384

Email: [rob.powell@lantek-systems.co.uk](mailto:rob.powell@lantek-systems.co.uk)

[www.lantek-systems.co.uk](http://www.lantek-systems.co.uk)



## Minimise downtime, maximise efficiency

HxGN SFx | Asset Management delivers easy to understand views of real-time data from your equipment with intuitive navigation and a customisable alert system.

By capturing and implementing vital production data from connected devices and systems, you can build more intelligence into your processes to make your shop floors more agile and autonomous.

**#makeitsmarter**

| Visit [hexagonmi.com](https://hexagonmi.com)

## Exciting rapidly emerging technology

Prima Additive launches in the UK and Ireland with a comprehensive line up of machining solutions

Prima Power UK Ltd has recently launched a completely new range of machinery solutions for Additive Manufacturing, produced by Prima Additive, the specialist division of the global Prima Industrie Group.

From a purpose-built innovation centre at the Prima Power Headquarters and Technical Centre in Turin, Prima Additive offer a range of solutions for both Powder Bed Fusion and Laser Metal Deposition technologies that draw from the group's long-established experience in manufacturing laser cutting and welding machines for industrial applications.

An exciting and rapidly emerging technology, Additive Manufacturing allows the production of complex components, utilising metallic powders fused via the thermal energy delivered from a laser. Powder Bed Fusion uses the laser to melt specific points on a layer of metallic powder,



Prima Power Laser Next 2141 3D Laser



Sample Additive Manufacturing Part, produced by Prima Additive

which is built up during the process to form the finished component. In Laser Metal Deposition, an alternative approach of directly applying the powder at the focal point of the laser is used, thus allowing the manufacture of much larger pieces that are only limited by the machine capacity, rather than the size of a powder bed.

For Powder Bed Fusion processes, the Prima Additive Print Sharp and Print Genius models feature a compact and easy to use solution with build volume capacities of up to 262 mm x 262 mm x 350 mm. The Print Sharp 250 utilises a single 200 W or 500 W power laser for a build rate of up to 30 cm<sup>3</sup> per hour, whereas the more powerful Print Genius 250 uses twin 500 W power lasers to achieve a faster build rate of up to 50 cm<sup>3</sup> per hour.

# PSL DATATRACK

Flexible Production Control software  
for subcontract precision engineers

Est.  
**1988**



[engsub@psldatatrack.com](mailto:engsub@psldatatrack.com)

[twitter.com/psldatatrack](https://twitter.com/psldatatrack)

[www.psldatatrack.com](http://www.psldatatrack.com)

08456 345931



Components with complex geometries can be produced with an excellent degree of accuracy and quality for a wide range of applications. Operation is via an easy-to-use, intuitive HMI and Prima Additive offer their own 3D Printing Suite software, with a range of powerful functions for quick file preparation, design change, part creation and slicing, reducing the time from design to manufacture.

Laser Metal Deposition manufacturing is undertaken on several already well-established Prima Power machine models, the Laserdyne 430, Laserdyne 795 and Laser Next 2141, all of which have been thoroughly proven in 3D laser cutting and welding applications across the highly demanding aerospace and automotive sectors.

Utilising a specialised head to provide the powder spraying and fusion at the focal point of the laser beam, the machines offer working volumes starting from 585 mm x 400 mm x 500 mm up to an impressive 2,100 mm x 4,140 mm x 1,020 mm. Laser power options range from 1 kW up to 6 kW and deposition rates are possible up to



Sample Additive Manufacturing parts, produced by Prima Additive

70 cm<sup>3</sup> per hour. The large working envelope of these machines offers

considerable versatility for applications ranging from R&D, rework and prototyping fully through to part manufacturing.

Prima Additive is able to offer both technologies into many industrial sectors such as aerospace, automotive, motorsport, rapid prototyping and medical. For maximum versatility, the machines can be used with a wide variety of metal powders that include aluminium, nickel, steel, cobalt-chrome and titanium alloys.

Complementing the machinery, Prima Additive also provides a host of additional services, tailored to suit the individual needs of each customer. Offering advanced expertise in process and application consulting, training, support, process monitoring and certification, Prima Additive takes a customer focused approach, ensuring that the often complex demands of each application are fully met.

**Prima Power UK Ltd**  
**Tel: 0844 4996241**  
**Email: [info@primapower.com](mailto:info@primapower.com)**  
**[www.primapower.com](http://www.primapower.com)**

## MIETrak Pro: The complete production control solution...



...for the Manufacturing and Engineering Industry

Contact us for a free no obligation demonstration  
 01527 576444 [sales@mie-solutions.co.uk](mailto:sales@mie-solutions.co.uk)

**mie solutions™**  
 MRP Production Control Software

[www.mie-solutions.co.uk](http://www.mie-solutions.co.uk)

# Customer quotation improvements help take Bedford CNC to the next level

For some small precision engineering companies, improving the administration that lies behind their production processes and manufacturing capabilities is not always necessarily the top priority. The main focus is often to ensure that the performance of machine tools is optimised and that parts produced are of the highest quality. Andy Soos of Bedford CNC, however, has taken an approach that prioritises all of the above areas and is consequently now in a strong position to take the business to the next level. This is all thanks to a number of wise investments and business initiatives, including the use of PSL Datatrack production control software.

“Through video testimonials I became aware of the many positive comments made by other engineering companies about the benefits of investing in PSL Datatrack,” comments Andy Soos. He decided to investigate further, specifically looking to speed up his method of generating customer quotations and make them look more professional.

“Preparing quotes was an area I knew needed addressing if we were to attract more customers to Bedford CNC. They were taking too long to produce manually because gathering all the information and calculating costs for each quote was time-consuming and prone to error. We were then manually typing up and sending the quotes to potential customers via email. They looked scruffy, had no visual identity of our brand nor did they reflect Bedford CNC’s core values of quality and good service,” explains Andy Soos.

Bedford CNC has an impressive engineering production capacity including a Haas CNC lathe, Bridgeport CNC machining centres and a Citizen L20 sliding head lathe. This is complemented by a CMM, together enabling the company to produce high quality finished components as well as providing first offs and inspection reports for companies within many different industries. Today, the aerospace, automotive, defence, electronics, general manufacturing and materials handling sectors are all

serviced as well as specialist work, such as producing parts for Spitfire restoration projects, further underlining the company’s precision engineering capabilities.

“We called in PSL Datatrack as they specialise in production control software for the subcontract precision engineering sector and would, in broad terms, understand in advance our business administration requirements,” continues Andy Soos. PSL visited on a number of occasions, obtained a full picture of our issues and what we wanted to achieve with quotations. They took away company letterheads, logos and other relevant information before making us a customised proposal based on investment in the PSL Datatrack Quotations module.”

The system was installed in August 2019, leading to a dramatic improvement of the quoting process and quotes can now be raised much more efficiently and professionally. Initially, all necessary customer contact details were entered into PSL Datatrack and can now be easily recalled at any time in the future in the event of re quoting a customer.

From there, it takes just a few clicks of the

mouse to raise the quotation. A quote number is allocated and descriptions and drawing numbers defined, then information on machining times and associated hourly rates to produce the parts is entered. The cost to the customer is automatically calculated and information on expected delivery time is included, subject to any variables such as material or subcontract supplier lead times. The system also ensures the correct drawing is stored against the quotation, eliminating the risk of human error. Multiple drawings can be linked as required and quotes for multiple parts for the same customer can be amalgamated into one quotation letter.

“We can now prepare about nine quotations in 20 minutes or less in total, whereas previously it may have taken a couple of hours or so. What’s more, when the quote is later converted into a firm order, we are ready to go as all the required production information is already in the system. I would never go back to manual quotes,” says Andy Soos.

Getting up and running with PSL Datatrack was easy, as Bedford CNC were trained on using the software remotely,

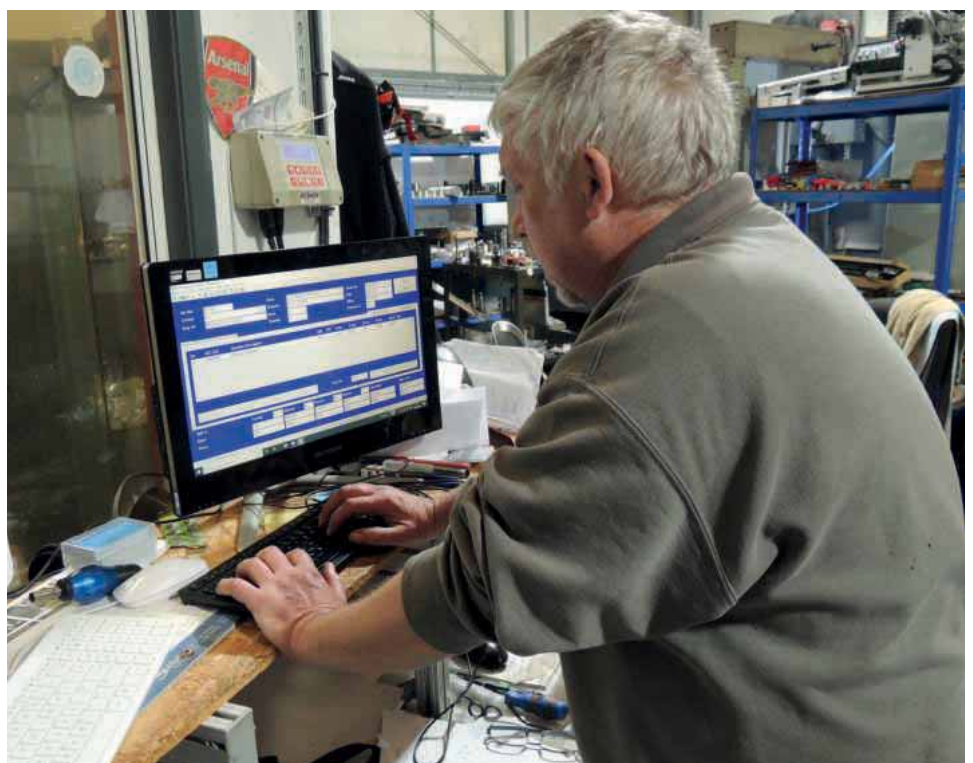

# PSL DATATRACK



using shared screens. After a couple of hours' tuition Andy Soos was ready to go live and discover for himself some of the other benefits of using the software. Any queries were immediately resolved through PSL Datatrack's telephone lines as part of ongoing support.

Bedford CNC has now gained several months' experience using PSL Datatrack and when the time is right will look to invest in additional modules such as Works Orders, Deliveries and Invoicing.

"That's the beauty of the modularity of PSL Datatrack. You can add more when you are ready and have confidence that they will integrate seamlessly with existing modules. I would recommend the system to any engineering company similar in size to us or indeed to those larger who are involved in

the production of multiple products for many different customers and want to cut right back on manual administration," concludes Andy Soos.

Alongside other business initiatives such as appointing new accountants, improving social media presence, investing in high quality machine tools and taking on a business coach, investing in PSL Datatrack has undoubtedly played a major role in taking Bedford CNC to the next level. Quotations are easier to generate and look highly professional, resulting in more business opportunities and, ultimately, more customers.

Prospec Systems Limited is the market leading author and supplier of PSL Datatrack production control software. The company was established in 1988 and its

friendly, experienced team has supplied solutions to manufacturing businesses for over 30 years. The offices are based in Bracknell, Berkshire.

Background skills in information technology, engineering, accounting and business management enable us to provide economic and effective software solutions.

PSL Datatrack is proud to support British Manufacturing and all its software is designed, developed and supported in Bracknell, Berkshire.

For more information, contact:

**PSL Datatrack**  
**Tel: 08456 345931**  
**Email: sales@psldatatrack.com**  
**www.psldatatrack.com**

## Mackart Additive supports NHS need for vital ventilator parts

In early March, the Government announced it was looking for businesses with the capability to support in the supply of ventilators and ventilator components, as part of its plan to fight the Covid-19 pandemic, now sweeping the UK.

Dr Iain Crossingham, respiratory consultant at Royal Blackburn Teaching Hospital's Chest Clinic, contacted a group of businesses that had come together to act as a fast-response consortium following the government's call to arms.

He had identified the need to increase available ventilator capacity by commissioning the design and production of a single-use, consumable exhalation valve, the type required to aid patients with breathing difficulties.

Specialists in mechanical component design and 3D additive manufacturing, Mackart Additive, were ready to respond. Following correspondence on the evening of Friday 27 March, a sketch of Dr Crossingham's idea for a life-saving valve was sent to Mackart Additive for consideration.

In a matter of hours, Mackart Additive developed a detailed 3D CAD model of the component, which was approved by Dr Crossingham for production to begin the very next day. Barely 12 hours later, on the morning of Saturday 28 March, the first 3D printed part had been completed and was soon on its way to The Royal Blackburn Teaching Hospital.

On receipt, Dr Crossingham began to test the part using clinical equipment. With strict flow and pressure standards to meet, the exhalation valve passed successfully first-time without any issues.

Steven McCarthy, managing director at Mackart Additive, says: "Mackart Additive is no stranger to tackling technical challenges against tight schedules. With in-house engineering, design and 3D printing capability, we are used to developing and manufacturing bespoke components and precision tooling for aerospace clients and Formula One teams, using 3D printing techniques.

Dr Crossingham says: "When the part arrived from Mackart Additive it worked



perfectly. Over recent days we have used the new exhalation valve to successfully ventilate a test lung, which is amazing. The fit on the connectors was perfect and held pressures to 40cmH2O while the intentional leak from the port passed the ventilator circuit test algorithm without any warnings. Brilliant work."

**Mackart Additive**  
**Tel: 0333 3350321**  
**Email: info@mackart-engineering.co.uk**  
**www.mackart-engineering.co.uk**



# Significantly faster waveform roughing in EDGE/CAM 2021

New and enhanced functionality in the latest release of EDGE/CAM CAD/CAM software from Hexagon, boosts customer productivity through lower computer processing time, and faster toolpaths.

A number of these productivity-boosts have been achieved through reducing calculation time by enhancing EDGE/CAM 2021's parallel processing capability. Two of the most popular machining cycles, Roughing and Profiling, benefit from improvements to the software's multi-threading technology algorithms.

EDGE/CAM's world-leading high-speed Waveform Roughing strategy is now significantly faster when generating toolpaths for both solid and wireframe components. Machining market and product manager Miguel Johann says: "Numerous benchmark tests show a 30 percent improvement in calculation times, compared to the previous version."

When using the Profiling cycle's Undercut function, savings of between 40 and 60 percent have been recorded, depending on the part's size and complexity. And improvements in the software's architecture give an average time saving of 70 percent on checking toolpaths with Machine Simulator when the software is initially launched.

A radical overhaul of the probing functionality revolves around eight new cycles, which deliver support for programming a variety of on-machine probing cycles. The cycles' NC output can be configured to support Hexagon's

existing m&h probing macros, as well as many other popular probing systems for different controls and native probing languages of Siemens and Heidenhain controls.

Following specific customer requests, six new or updated commands have been introduced into the Inspection operation, including the ability to globally edit existing features, and to specifically control the layout of both Linear and Rectangular Array features.

One of EDGE/CAM's most used strategies, the Face Mill Cycle, now offers better toolpath control, reductions to cycle times, less tool wear, and can potentially increase machine tool longevity.

As well as time savings, the new Cut by Region option deploys a more even toolpath, completing each segment of a component before moving on to another region. Another newcomer, Outside To In strategy promotes more intelligent toolpaths, as well as reducing cycle times. Previously, when set to either Climb or Conventional, the face mill cycle took longer as it moved from left to right in readiness for the feed movement, but now, closer cutter contact reduces that time, while a new Overlap Edge function guarantees no wasted cutter passes, and no surplus material left on a face.

Extra Lead In/Out functionality for lathes gives more lead control during the secondary movement of the Finish Groove cycle. Applications engineer Mike O'Neill explains: "Groove features come in all

shapes and sizes, and aren't always symmetrical. EDGE/CAM 2021 includes a Secondary Lead Move dialog, meaning that as the cycle completes the opposite side of a groove feature, the user can now deploy unique Lead In and Lead Out movements."

A further turning-related enhancement includes more control when working with angled turning tools. Two new modifiers, 'Corner' and 'Lock,' will enable a 'dynamic gauge point,' which maintains the same position in relation to the insert at all orientations.

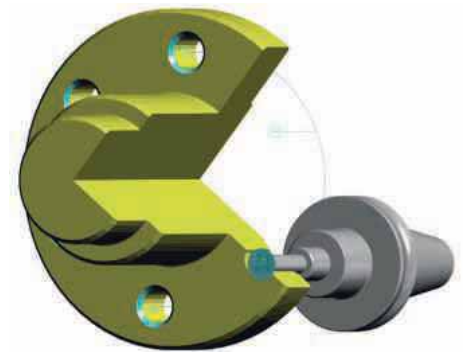

Dovetail tool cutters, which were introduced in the previous version of EDGE/CAM, can now be used with a Profiling cycle in both milling and turning environments. Solid Features and Faces can be selected in conjunction with the Undercut command, for back-facing and other collision-free toolpaths. Also, in response to customer requests, the Protect Solid function found in the Profiling cycle, has been enhanced to give safer toolpaths when using the Multi-Pass and Pick Solid Face commands.

The 2021 release includes two important new machine tool configuration features to harness best practice. Variable pitch and multiple axis support on tool mounting blocks have been introduced in Linear Turret Lathes kinematics. Using a simple switch in the Code Wizard to stipulate the exact position of numerous tool stations on a turret, while clearly showing this in the Machine Simulator.

Multi-Task Machine Tools' can now support cutting tools mounted inside Angle Head attachments. This type of tool configuration has been used in EDGE/CAM's milling environment for a number of years,

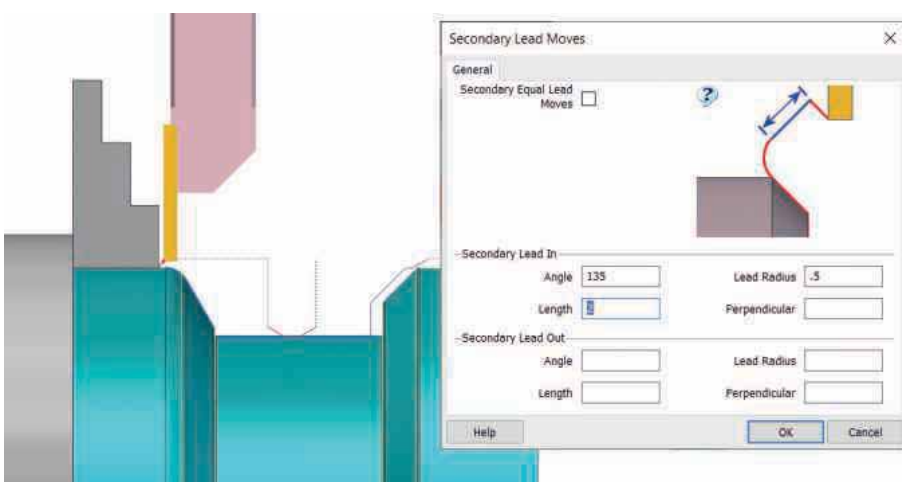

so MTMT users are benefiting from a mature feature that's been thoroughly tried and tested.

Finally, Wire EDM includes a new strategy to the Wire Set-Up command and extended controller support. The 'create pocket rough tag and finish files' strategy supports industry best practice and allows users to create four separate NC files, for Pocketing, Roughing, Tag creation, and Finishing. Technology tables for Charmilles and ONA AV have been added, along with enhanced support for a range of Mitsubishi controllers.

For more information, visit [www.edgcam.com](http://www.edgcam.com).

Hexagon is a global leader in sensor, software and autonomous solutions. We are putting data to work to boost efficiency, productivity, and quality across industrial, manufacturing, infrastructure, safety, and mobility applications. Its technologies are shaping urban and production ecosystems to become increasingly connected and autonomous, ensuring a scalable, sustainable future.

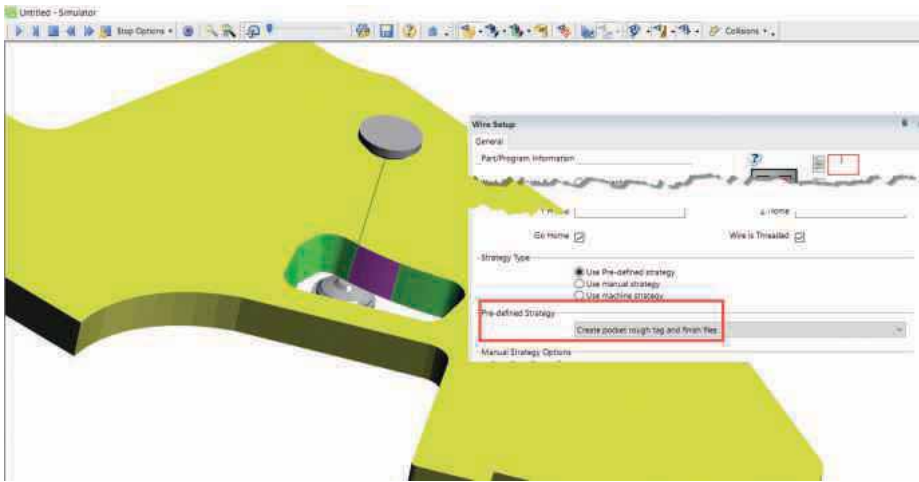
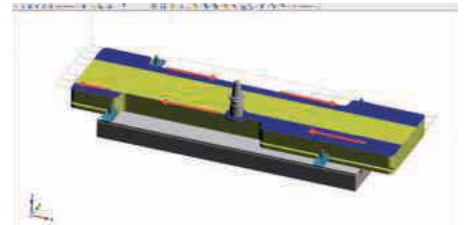
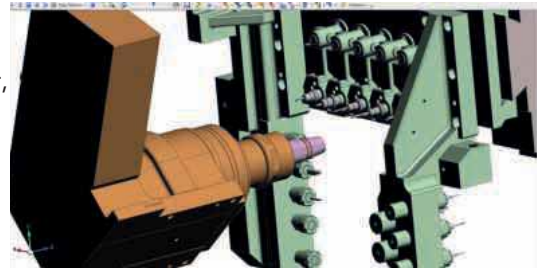

Hexagon's Manufacturing Intelligence division provides solutions that utilise data from design and engineering, production and metrology to make manufacturing smarter. For more information, contact:

**Hexagon Manufacturing Intelligence**  
**Tel: 01242 542040**  
[hexagonmi.com](http://hexagonmi.com)

# Gc GibbsCAM®

## MULTI-TASK MACHINING

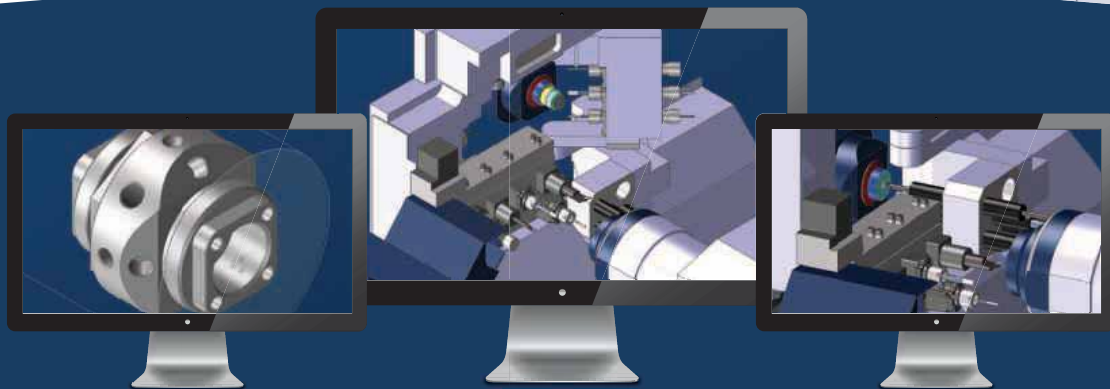

GibbsCAM delivers many new capabilities to improve and accelerate every part of the programming process, taking parts from concept to creation in record time.



Tech CAD/CAM - GibbsCAM UK distributor since 1997  
 ☎ 01284 754781 🌐 [www.techcadcam.net](http://www.techcadcam.net) ✉ [info@techcadcam.net](mailto:info@techcadcam.net)

# Complex forms are no longer a problem with Tebis CAD/CAM 5-axis roughing

5-axis roughing has been designed for a simple and fast roughing operation that removes the maximum amount of material in a single operation by utilising full 5-axis motion. There is a huge time saving on the operation when machining on non-linear areas.

Andrew Walters, application engineer from Tebis UK explains: "Traditionally roughing would employ small step-downs with a larger width of a cut calculated in a water-line fashion method. With Tebis, we will use a 5-axis simultaneous motion to allow us to get down into complex forms. In the addition to the traditional water line method, Tebis can use adaptive roughing."

As well as an increase in tool life and operation accuracy by giving a more consistent volume of roughed material on a part, the finishing tools need to do less work. An additional benefit of this process is a more consistent volume of roughed material on a part.

## 5-axis radial roughing for mill/turn all in one package

Tebis CAD/CAM is capable of utilising 5-axis adaptive roughing in a conventional milling environment, but it can also apply advanced 5-axis roughing strategies to mill/turn machines as well. By applying these operations in turn/mill processes, Tebis will maximise material removal and tool life whilst minimising the cut time.

## Automation CAD/CAM control surface creation

In most CAM system it is necessary to create a control surface when programming 5-axis machining operations. In Tebis CAD/CAM this function is automatic, with the control surface being created in the background by selecting only the surface you wish to machine. This will give a highly accurate creation of vectors for controlling tool and head direction. There is no need to switch between CAD and CAM packages which saves time by not having to create the control surface data and also increasing consistency and accuracy.

## Template automation

Tebis CAD/CAM software is capable of using template and automation in 5-axis which is able to give consistent toolpaths and cutting conditions by using standardised parameters. This way all

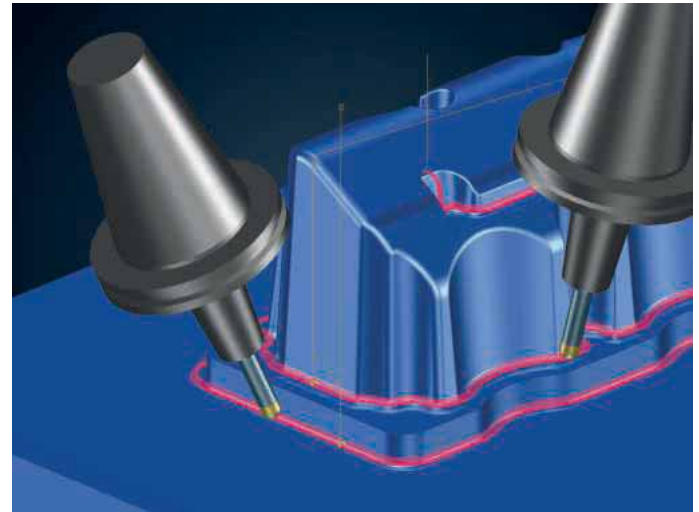

output programs are using the same stepovers, lead ins/outs and safety clearances. Tebis offers reliable processes and make quality highly controllable and repeatable.

## Virtual Machine Technology

Tebis software uses Virtual Technology at three stages of the process: planning, programming and verification.

The first stage is the planning process; the machine operator needs to know if a component which is planned to be machined will fit on the machine bed. This can be checked along with the optimum setup position for the tool tilt directions and check cutting tool lengths required. If this is not done like other systems, machine limits will most likely be hit.

For programming, Tebis CAD/CAM uses the Virtual Machine for calculation of toolpaths as it contains the machine rotational limits. It is possible to see when programming if a toolpath angle can be achieved on a 5-axis machine. Tebis will not allow creation of a toolpath if it is not achievable in reality.

The last of the three stages is the process of verification, which is the toolpath checking. This prevents any collisions, not just against the cutting tool and a component, but the whole machine, its limits, shields, barriers, fixtures and any other component setup on the machine at the same time. If there is a problem, it is easy to modify and recheck during the programming process.

Andrew Walters explains: "Other software companies are unable to check the connection between toolpaths. Once the toolpaths are completed, the machine takes over the control, rotates and repositions the tool correctly. Tebis software has the full control over the movements between the end and the beginning the next toolpath. These are fully programmed, controlled and fully verified in the Virtual Machining Technology."

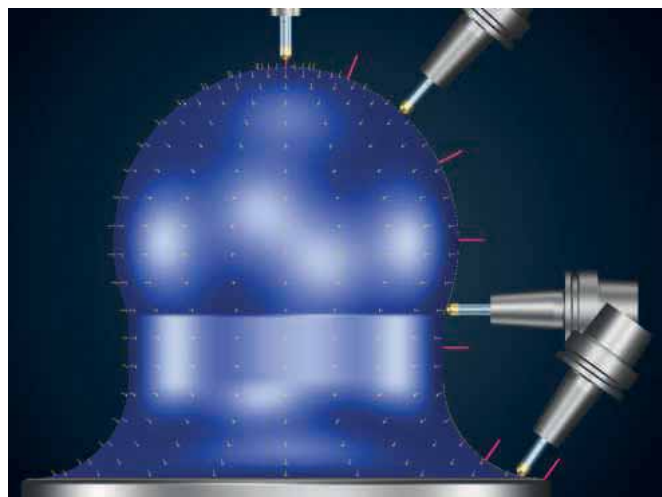

**Tebis (UK) Ltd**  
**Tel: 024 76 158178**  
**Email: [info-uk@tebis.com](mailto:info-uk@tebis.com)**  
**[www.tebis.com](http://www.tebis.com)**



# hyperMILL breathes life into COVID-19

Maztech Precision Engineering was founded just six years ago by Wayne Bouchier to specialise in multi-axis CNC machining and, during this period, the company has earned a reputation for producing quality components. Customers of the Letchworth business now include leading aerospace, automotive and Formula 1 companies.

With F1 teams so heavily involved in the Coronavirus (COVID-19) ventilator project, reputable technology partners like Maztech have been making parts for ventilators.

"My strategy has been to invest in the best of everything and this includes Mazak machining centres, ITC cutting tools and of course the hyperMILL® CAM system from OPEN MIND Technologies," says Wayne Bouchier.

It is this strategy that has seen Maztech involved in the government response, winning an order to produce 7,500 aluminium tube manifold components. The company has recently been running its four Mazak machining centres 24/7.

"The tube manifold is a relatively simple 3-axis part, but with such quantities we needed to design new fixturing to conduct multiple setup machining. Using the Linear Pattern feature in hyperMILL, we have been able to effectively 'copy and paste' the machining cycle from one position to the next on our machining centres," says Wayne Bouchier. "On one of our machines, we now have 16 WNT ZSG4 vices with suitable fixturing setup for non-stop machining. The hyperMILL programme for each part is



The Maztech machine shop filled with the latest Mazak machining centres

simply 'copied and pasted', not just across each fixture, but also across all of our machines.

"Our programming times are at least 35-40 percent faster with hyperMILL. One example of this is the Mirror function within hyperMILL. More than 30 percent of our work has a left and right-hand variant. For these parts hyperMILL and its Mirror function is slashing programming times from hours to minutes."

For Maztech to produce complex components with confidence, its engineers have modelled all workholding accessories, such as all vices, vice jaws and chucks, and created a template for each. "With hyperMILL, if you put good data in you get good data out. If you set up your tools exactly as they are set up in hyperMILL, run a



COVID-19 ventilator parts ready for machining

collision check and the software says that there is no collision, you're 99 percent guaranteed there won't be a collision," explains Wayne Bouchier.

"So, when you first programme a job, you open the template and select the vice and the jaws and pull that into your job. Straight away, you are collision checking against your vice and jaws as your machine is modelled up. Especially on the 5-axis machine with its tilting spindle, you know that the spindle isn't going to catch a table, as it collision checks everything."

In answer to the question as to whether he thinks the CAD/CAM hyperMILL package is as important as the CNC machines, Wayne Bouchier claims it's more so: "I think without a decent CAD/CAM package you could have the best machine in the world but if you've got nothing to drive it, it's an absolute waste of time."

**OPEN MIND Technologies UK Ltd**  
**Tel: 01869 290 003**  
**Email: info.UK@openmind-tech.com**  
**www.openmind-tech.com**

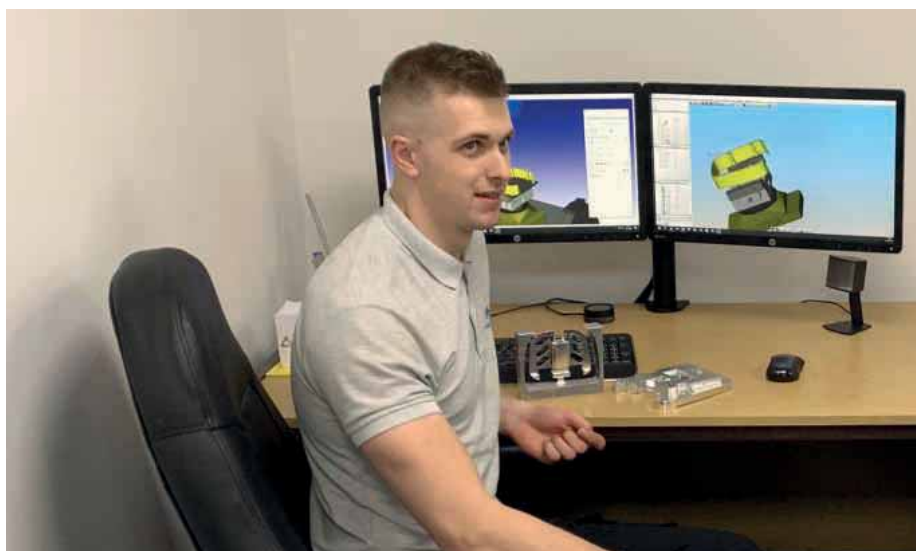

Maztech engineer using hyperMILL®

# Investment delivers a new dimension

## FC Laser adds another dimension to the art of precision laser cutting

FC Laser, the fastest growing precision laser cutting company in the UK, has committed to a significant and ambitious £2.5m investment plan, which will include a facility redesign with optimised layout, the introduction of two new 12kW Bystronic ByStar Fiber lasers, a fully automated Tower Storage System and fully automated paint line.

This investment has already commenced, with the first 12 kW Laser already installed. The entire project will be completed including full operational capability by the end of 2020. This investment is testimony to the FC Laser team. Despite the challenging and unprecedented times, FC Laser is pushing forward with a significant and ambitious investment because of a great belief in its people, product and service offering to its customers.

Managing director Danny Fantom comments: "Our innovation and dedication to customer service has been the key factor in our decision to commit to a significant investment in two ByStar 12 kW laser cutters and a brand new state-of-the-art automated Tower Storage System. Once installed we will be the only laser cutting company in the country to operate a fully automated Tower Storage System that is connected to two powerful 12 kW Lasers.

"This investment adds to our current laser cutting capabilities supporting and complementing our five Bystronic press brakes. If you include our top of the range tube laser and a new automated paint line, we believe we will have the most efficient, effective and comprehensive range of capabilities available in the marketplace today.

"The investment will allow us to become more efficient, which in turn will create a

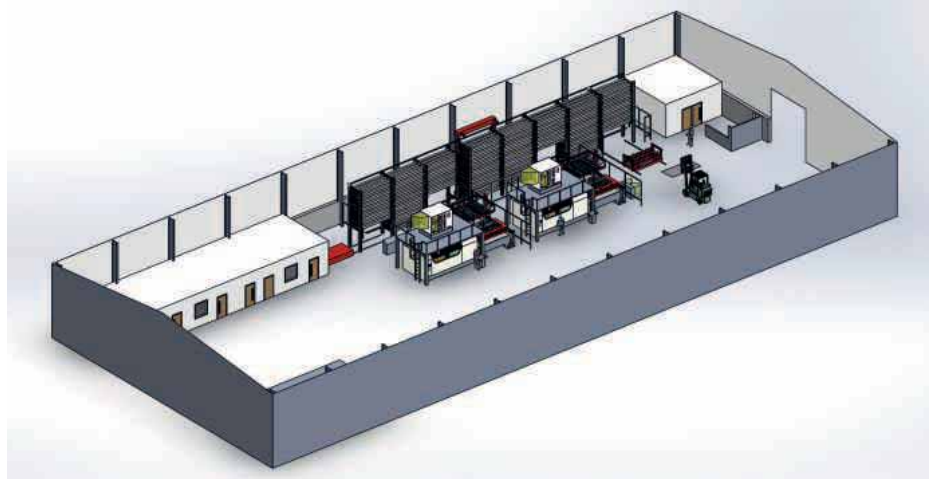

valuable window of opportunity to focus on the FC Laser "Ideal Team Player" philosophy. Additional staff training and development will further enhance our already skilled, talented and dedicated workforce. We will also continue our focus on talented people by inducting several apprentices on our successful apprenticeship scheme.

"We have always strived to give our customers the best possible service, by continuing to invest in our people as well as the best available technology and software we will ensure this continues."

### **ByStar Fiber laser cutter delivers new levels of efficiency and production flexibility**

FC Laser has introduced the next level of power in fibre laser cutting: the innovative, high performance ByStar Fiber laser cutter with 12 kW fibre source. With high cutting dynamics, thin to thick cutting capabilities, seamless automation solutions and intelligent sensor technology, which is fully integrated with their very latest software systems.

### **Exceptional quality in thick plate cutting with BeamShaper**

The BeamShaper allows for an ideal adjustment of the laser beam profile for cutting thick steel plate with diverse material characteristics. In steel materials up to 1.125", the new function raises the quality of the cut surface and increases the cutting speed by up to 20 percent when cutting with oxygen. BeamShaper delivers:

**Power and Speed** – the ability to cut 30 mm mild steel up to 20 percent faster.

**Quality** – great edge quality in 20–30 mm mild steel with easy part removal.

**Flexibility** – a high variety of material can be cut easier with better quality finish.

**Reliability** – wider kerf for easy unloading with higher focal tolerance in thick mild steel, delivering process safety.





## More key benefits include:

Automatic Nozzle changing facility combined with the very latest software systems and the automated warehousing will allow FC Laser to deliver a 25 percent increase in production capacity.

The cutting head has spot control which ensures it cuts the complete thickness range without compromise, with only one focus lens ensuring no focus shift for process stability.

Detection Eye delivers extremely fast and accurate edge detection, reducing non-productive time.

Cut control – no waste with automatic cut off and the shortest piercing time through pierce trough detection.

## State-of-the-art automated warehousing system

The new tower system will allow FC Laser to multiply the efficiency of the production facility, reduce the processing times of the individual projects and optimise the use of the extensive production capability. Key features are: extraordinary compactness; fully customised layout and dimensioning; interfacing with computer system to allow the real time management of stocks and the flexible management of the production plans; flexible enlargement due to the expandable modularity.

Bystronic UK Ltd managing director Dan Thombs comments: "At Bystronic we aim to be industry leaders in technology, providing

equipment and software that help our customers stand out in a competitive market. Our strategy is to build close relationships with our customers, to understand their business and to provide the best possible solutions to meet their needs.

"It is always great to work with FC Laser, Danny Fantom and his team, who have a similar outlook, are focused on ensuring they operate the latest equipment, technology and software to deliver on the commitment to their customers.

"After fully integrating their production management systems with Bystronic Plant Manager software last year, FC Laser will further enhance their production capability in 2020 with the introduction of their first ByStar 12 kW machine in June and have now become the first UK manufacturer to order a second 12kW machine.

"To maximise the effectiveness of these

class leading machines, FC Laser will introduce a fully automated Tower Storage System in December. The Tower Storage System will enable FC Laser to realise the maximum benefit from the performance of the two 12 kW Lasers and bring major improvements to the process flow, logistics and efficiency of labour. When combined with the investments made in operational software it will place FC Laser in a strong technical position for the future."

**Bystronic UK Ltd**  
**Tel: 0844 848 5850**  
**Email: dan.thombs@bystronic.com**  
**www.bystronic.com**

**FC Laser**  
**Tel: 0115 944 3428**  
**Email: sales@fclaser.co.uk**  
**www.fclaser.co.uk**



# Up to four times more cut speed with AMADA ENSIS high-power fibre laser

Chippenham-based De Marchi Engineering, a specialist in stainless-steel fixings for the construction industry, has invested in an automated AMADA ENSIS-3015AJ 9 kW fibre laser cutting machine to help it profile parts up to 25 mm thick. The arrival of the new machine has seen Di Marchi witness a three- to four-fold increase in cut speed for the components its processes. Since installation in April 2019, the ENSIS has been complemented by the acquisition of two new high tonnage AMADA HFE3i series press brakes.



De Marchi Engineering was established by Richard Collins in 1993 and remains a family-run business to this day, with sons Paul and Mark currently at the helm. The company can supply bespoke fabrications or high-volume batch work, all with the quality assurance of ISO9001. Notably, De Marchi is a manufacturer of CE approved structural steelwork to EN1090-1:2009+A1:2011 EXC2. The company serves construction companies, building restoration specialists, concrete pre-casters, stonemasons, civil engineers, playground equipment manufacturers and fall-arrest system specialists, to list but a few.

At De Marchi, continuous investment in the latest technology provides higher levels of quality, faster turnaround and a continually expanding range of fabrication capability. With stainless-steel brackets commanding around 80 percent of output, core to the company's offer is its profiling technology.

"Originally we used plasma cutting and waterjet, but three years ago we added our first laser cutter with the AMADA LC-F1 and loading tower," confirms Paul Collins.

Despite functioning perfectly and fully meeting expectations, the recent arrival of a new business deal meant that even more laser-cutting capacity was required.

"We managed to secure an exclusive supplier deal with our biggest customer, which meant the 4 kW LC-F1 would not be able to keep pace with the extra throughput required as we were already close to capacity," adds Paul Collins. "Originally, we thought about simply adding a second LC-F1, but in all honesty we didn't have the space. Furthermore, oscillator output had moved on and we knew that the 9 kW AMADA ENSIS could offer us a lot more."

De Marchi spoke with AMADA about the

availability of an ENSIS and was pleased to learn about a machine that had just arrived at a port in Belgium. Coupled with the availability of an ASLUL twin-loading tower at AMADA's UK headquarters in Kidderminster, the company decided to part-exchange its LC-F1 machine.

The AMADA ENSIS-AJ 9 kW fibre laser cutting machine with ASLUL-3015 twin tower automation system (the first such system in the UK) has a maximum working area of 3 x 1.5 m. As well as processing stainless steel up to 25 mm thick, the machine can also handle mild steel up to 25mm and aluminium up to 25 mm.

"Since it was installed in April 2019, the



9 kW ENSIS has been providing us with up to four times more cut speed and capacity, which means we're able to meet the requirements of our new customer supply arrangement, with room to spare," says Paul Collins. "We use the machine to produce stainless-steel brackets in thickness ranging from 2 to 25mm. Moreover, we can store up to 30 tonnes of material in the loading tower for 24/7 cutting, which is hugely beneficial."

De Marchi is also using the telemetry available with AMADA V-factory software to capture live data and let the company utilise performance statistics and analysis reports.

"The reporting is fantastic and has brought home just how quick the ENSIS is," continues Paul Collins. "For instance, we've discovered that some days we're getting through 24 tonnes of material cutting, which is quite something."

De Marchi processes batches from 1-off up to a few hundred and makes many components to order. Notably, the arrival of the ENSIS has had a significant impact on quality, particularly on thicker stainless-steel parts. Central to the advanced capability of ENSIS-AJ high-power fibre lasers is AMADA's Variable Beam Control technology, whereby the laser beam is

automatically adapted to deliver stable cutting across all material types and thicknesses.

"We could see that the quality was better with our profiled components, so we decided to try and enhance our subsequent bending capability, opting to install two AMADA press brakes," says Paul Collins.

The two machines, an HFE3i-1703 8-axis model (170 tonne 3 m capacity) and an HFE3i-4004 long-stroke press brake (400 tonne, 4 m capacity) arrived in August 2019. The company has also installed AMADA VPSS 3i Bend/Blanking software system to help simplify and speed programming. Thanks to the software, files can be shared between the press brakes and the laser cutter, aiding continuity.

"Traditionally, most of our brackets have been fairly simple, featuring one or two bends," explains Paul Collins. "However, in recent years there's been a distinct trend for more complex bracketry, and many of our current orders simply could not be processed efficiently on the press brakes we had previously. In short, the new AMADA machines, press brakes and laser cutter, have cut our lead times, which is essential in the highly competitive market of today.

Short lead times are a major differentiator for De Marchi, along with consistent, right-first-time quality. These are our customer commitments."

Three years ago De Marchi took on a second premises on the same trading estate and has not looked back. In the time since, the company has grown sales around 30 percent year-on-year, effectively doubling its size. Today, De Marchi has 30 employees and expects this number to rise further as it continues to capture market share.

"The market is tough, but with the right approach to customer satisfaction, and the right investment in the latest manufacturing technologies, it's possible to thrive," concludes Paul Collins. "Our decision to invest in AMADA machines is certainly paying dividends and we're really pleased with the progress we've made. Furthermore, AMADA's support has been great from the outset; they are always there if we need them, either in person, or over the phone."

## AMADA

Tel: 01562 749500

Email: [cathryn.morris@amada.co.uk](mailto:cathryn.morris@amada.co.uk)

[www.amada.co.uk](http://www.amada.co.uk)



**EVOLUTION  
IN POWER**

## Laser Next 2141

Prima Power has pushed the excellence of the **3D fiber laser line** to a new level. **Laser Next 2141** is born to match any manufacturing need. It is a multipurpose solution designed and developed for both large-part processing and small productions. **Welcome to the next generation of 3D fiber laser technology.**

[www.primapower.com](http://www.primapower.com)

[in](#) [v](#) [f](#)



# TLM announces new partnership with BODOR

One of the UK's leading suppliers of laser technology and systems, TLM Laser continually evaluates opportunities to enhance its comprehensive product portfolio, in order to be able to offer the most technologically advanced and cost-effective solutions to a wide range of laser processing applications.

In a new development, the company has announced a partnership agreement with BODOR Laser, to distribute the company's range of high precision metal laser cutting systems within the UK and Ireland.

An advanced domestic supplier within its home market of China, BODOR Laser specialises in laser systems applications and integration. The company manufactures a wide range of flat-bed laser cutting and tube processing systems, designated CE compliant from TUV, with working envelopes ranging from 600 mm x 600 mm up to 4 m x 2 m for its flat-bed systems and up to 6.5 m for tube processing.

One example of the systems which will now be available from TLM Laser is the i3 Linear. The system features a 360 degree fully enclosed design surrounding the working area, which provides a safe working environment by isolating both fumes and laser radiation. With a working area of 600 mm x 600 mm, the system is available with a choice of laser power: 3,000 W, 2,000 W, 1,500 W or 1,000 W and offers X/Y-axis repositioning accuracy of 0.004 mm, and maximum axis travel speed of 80 m/min. The system is also available with options on laser sources from IPG or Maxphotonics and other features available include an auto-focus laser head which also incorporates anti-crash protection.

TLM Laser director Andy Toms comments: "We are delighted to announce this partnership with BODOR Laser to distribute their range of high precision metal laser cutting systems here in the UK and Ireland. With a full range of systems for flatbed cutting and tube processing, this range will complement our existing portfolio of laser processing systems and open up new business opportunities for TLM."

TLM Laser will be able to deliver new machines within 60 days from order, and customers can rely on UK-based spares stockholding, the full support of TLM service technicians and a three year warranty.

Founded in January 2006, TLM-Laser Ltd



The i3 Linear - just one of the range of BODOR high precision metal laser cutting systems now available in the UK from TLM Laser

are a dedicated laser service company, providing a second to none service and maintenance program which we can implement to best suit our growing customer demands.

Located regionally throughout the UK, the company provides a quick and efficient service, whether it be a preventative maintenance contract or emergency breakdown cover.

A team of highly trained and experienced engineers have vast experience on a complete range of lasers, whether it be lamp pumped lasers, diode pumped or CO<sub>2</sub>, and will endeavour to maintain and extend TLM's growing reputation at the forefront of the laser servicing and repair industry by carrying out scheduled maintenance visits as well as providing call out cover.

A large stock of spare parts allows TLM engineers to be committed to putting the customer first and to gain an exceptional level of customer confidence across many industries. Whatever your industry sector, TLM Laser will meet your requirements first time every time.

TLM Laser also supplies a wide range of laser safety equipment, spare parts, fume extraction, chillers, training, consultancy and subcontract laser marking. It also supplies a varied range of second-hand laser systems which are available in "as is" or fully refurbished condition.

The company now offers a complete



range of laser products from some of the leading names in laser technology. FOBA, Innolas, IPG, Univet, LPKF, Universal, BOFA, Univet, ALPHA LASER, LasX, 4Jet, Richter and IPG Photonics are names immediately recognised globally within the laser industry for the highest of quality and outstanding customer service, all supported by experienced and highly trained engineers to ensure your equipment generates the maximum in productivity.

TLM Laser prides itself on being a solutions company. With its long-term experience and cutting-edge expertise, it understands its customers' needs and tailors its services to meet them.

**TLM Laser**  
**Tel: 01527 959099**  
**Email: [sales@tlm-laser.com](mailto:sales@tlm-laser.com)**  
**[www.tlm-laser.com](http://www.tlm-laser.com)**



# How Luxinar is helping the fight against Coronavirus

Luxinar, the global laser manufacturer, is proud to be supporting a number of its customers, partner organisations and colleagues in the fight against Coronavirus.

Customers of Luxinar in the food & beverage and medical device industries are experiencing an increasing demand for their products in relation to COVID-19 which has led to increased orders for Luxinar's CO<sub>2</sub> laser sources. Other customers are ramping up or switching production to respond to the increased demand for coronavirus related products. These include the 24-hour injection moulding facility of Hull-based Advanced Plastics and the manufacturing sites of a global cleaning product supplier.

A major partner of Luxinar, employer-led school Ron Dearing UTC has supplied Perspex sheets to Luxinar so that colleagues in the company's applications laboratories can laser cut and engrave visors. This is in support of the Hull school's initiative to create face shields for key healthcare workers battling coronavirus.

Also, in response to the UK's National Health Service (NHS) call for 3D printed

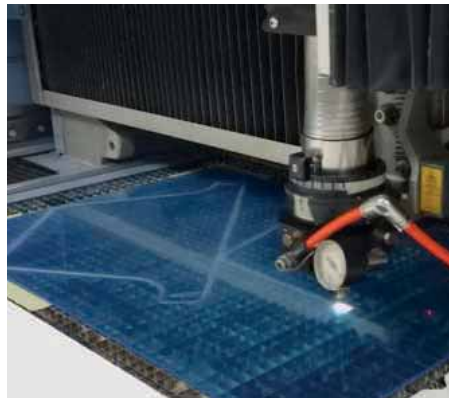

parts, colleagues at Luxinar are using printers that they have either borrowed or made in-house to produce face masks for NHS health workers throughout the country. Luxinar is supplying the materials and the 3D printed parts are being sent to a company for assembly and sterilisation before being passed to the NHS distribution hub.

Darren Taylor, senior manufacturing engineer at Luxinar and in charge of the project, says: "I have been astounded by the response and support I have been given

through this activity. It really makes it all worthwhile."

Luxinar has a singular focus: developing laser technology to enhance our world.

Like a laser that channels light into a single, powerful beam, it focuses on improving the lives of its customers. This allows it to create solutions to meet every single challenge, from heavy industry to delicate, high precision applications. It supports the laser technologies of yesterday, focuses on today's and pioneers those of tomorrow.

Luxinar has been at the forefront of laser technology for over 20 years and is a leading manufacturer of sealed carbon dioxide (CO<sub>2</sub>) laser sources up to 1,000 W and, more recently, femtosecond laser sources. It currently has an installed base of over 18,000 lasers worldwide in industrial applications environments.

**Luxinar Ltd**  
**Tel: 01482 650088**  
**Email: sales.uk@luxinar.com**  
**www.luxinar.com**

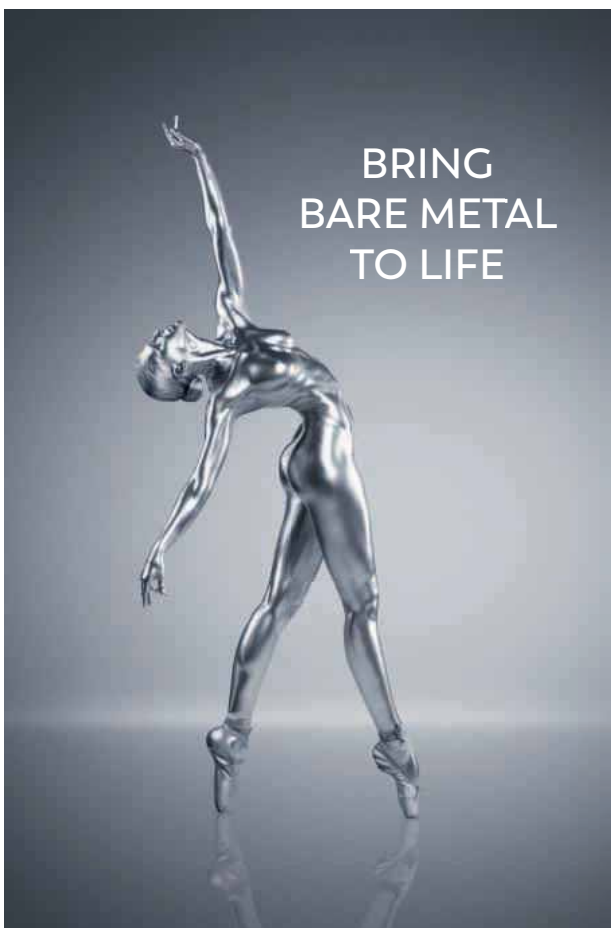

## LYNX FIBER LASER

Cost-efficient laser processing

Striking the perfect balance between performance and price, Lynx processes a wide variety of materials and thicknesses at an optimal cost per part. Advance your business with this capable, reliable and flexible fiber laser cutting machine:

- Integrated touch screen control and drive system
- 2, 3 or 4 kW IPG fiber laser source
- Automatic focal adjustment for 3 and 4 kW
- Sheet sizes 1.5 x 3.0 and 4 x 2 m
- Optimal cost per part

We help you bring bare metal to life: [lvdgroup.com](http://lvdgroup.com).

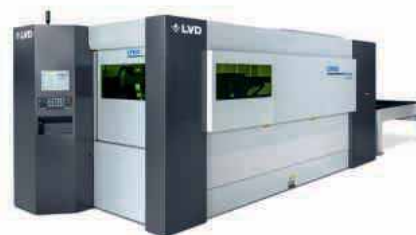

SHEET METALWORKING. OUR PASSION, YOUR SOLUTION

INTEGRATE

BEND

PUNCH

LASER

# Storage and sawing systems upgraded and automated

Since 1993, storage and sawing technology from KASTO has provided dependable service to hydraulic equipment manufacturer Liebherr-Components Kirchdorf GmbH. However, to meet increasing demand for its hydraulic cylinders, the company decided in 2019 to modernise and expand its production systems. So KASTO was commissioned to upgrade the existing storage system for steel bar and tube, as well as one of a pair of bandsaws, and install a customised robotic handling system.

Liebherr-Components has specialised in the production of hydraulic cylinders since 1958. Every year approximately 75,000 hydraulic cylinders, suspensions and system solutions for cylinders leave the plant to be used worldwide.

Stefan Lützel in the industrial engineering department at Liebherr-Components recalls: "A KASTO cassette storage system with 733 locations, an automatic cantilever arm and a large bandsaw from the KASTOhba series provided reliable service for 26 years.

"Until recently, a production circular saw of a similar age from the same manufacturer was also in use. However, we granted this saw a well-deserved retirement, as in 2016 we modernised our sawing technology and increased cutting capacity to 430 mm diameter with the addition of a KASTOtec SC 4 bandsaw, which is particularly effective at processing difficult-to-cut materials.

"The saw is able to operate with either a high-speed-steel or a carbide blade and is equipped with the KASTO Performance



Since 1993, Liebherr-Components Kirchdorf GmbH has relied on KASTO for storage and sawing technology

Cutting (KPC) package, which includes improved band guidance and vibration absorption for even higher cutting efficiency."

The bar storage system and KASTOhba bandsaw were still in good mechanical working condition, but the drives, measuring systems, controls and cabling needed modernising. Kasto offered a turnkey package to update them as an economical alternative to replacing these two pieces of capital plant and at the same time bring safety features up to current standards.

Furthermore, Liebherr-Components together with KASTO developed a custom-made solution to automate the handling of cut pieces with an industrial robot moving between the two saws on a linear track. The robot is equipped with several exchangeable magnetic grippers able to pick-up various cut lengths weighing up to 350 kg from the sawing machines.

Along the linear axis there are 18 storage locations for pallets and containers, the position of each being stored in the robot's control system. The cut pieces are finally transported to elsewhere within the factory by lift truck for further processing.



The high-performance KASTOtec SC 4 bandsaw purchased in 2016 is designed to process larger diameter stock, in particular solid and difficult-to-cut materials

Stefan Lützel says: "It was a major advantage having a single partner undertake all this work, as it made communication easy and avoided having to coordinate the activities of different suppliers.

"This was especially important as we had to carry out the work while the factory continued operating, without introducing too much disruption. Thanks to excellent organisation by KASTO, everything ran smoothly."

The benefits to production within the Kirchdorf factory are evident. One



The original KASTOhba bandsaw was still mechanically sound, so in 2019 it was refurbished along with the existing KASTO storage system for steel bar and tube



improvement is a lowering of the noise level in the working environment, as the robot places cut pieces quietly in their designated



The saw features a cutting range of 430 mm and can operate with HSS or carbide bandsaw blades

location whereas before they used to drop into a bin and every time make what Stefan Lützel described as "a horrible noise". He added that for the same reason, chrome plated material remains undamaged after it is sawn.

Further improvements include an ability to undertake material cuts up to three metres in length, a higher quality of cut than previously, shorter processing times, minimisation of waste and a significant increase in production efficiency.

An operator simply enters a cutting order at the control, whereupon the operating gantry crane of the storage system automatically transfers the required bar to one of the two saws, where the material is cut and the pieces handled and sorted, again without manual intervention. It is not only a safe operating environment but also one in which long periods of unattended production are possible.

Since it has been in operation, the system has run reliably without any noteworthy disruptions and with high availability, according to Stefan Lützel. He also observes that if any problems do arise, the equipment can be monitored remotely via their modern



An industrial robot has been installed to pick up various workpieces cut by both saws using one of four automatically exchangeable magnetic grippers

control systems by engineers at KASTO's headquarters in Achern.

**KASTO Ltd**  
**Tel: 01908 571590**  
**Email: sales@uk.kasto.com**  
**www.kasto.com**

## The BEHRINGER GROUP Stronger than ever together



**STRONG and EFFICIENT**

Behringer Ltd, part of the Behringer Group of companies, offer a broad range of machines from straight cutting, mitre cutting to circular sawing machines and a comprehensive range of the Vernet Behringer structural steel processing machines.

**STRONG** and built with solid cast iron parts and highly **EFFICIENT** due to high cutting performance and low maintenance costs.

We are happy to support you with Service, Spare Parts and Machine requirements.



Behringer Ltd 01296 668259 info@behringerltd.co.uk www.behringerltd.co.uk



# New mitre cutting bandsaw

High cutting rate, simple handling and precise mitre cuts make for an exceptional cost-per-cut ratio

Behringer Saws has introduced a new model to its HBE series. The HBE320-523G mitre cutting bandsawing machine, available in automatic and semi-automatic for all applications, ideally combines the benefits of modern high-performance machines for individual sawing applications with unique, proven Behringer features. The HBE320-523G is the entry level model into a whole new performance category.

The wide range of features included on the HBE320-523G saw consist of band guiding components made of vibration-dampening grey cast iron, an electrically powered chip brush, sensitive cutting pressure control, a wide mitre cutting range, spray mist cooling system and more. The sensitive cutting pressure control system allows the saw to cut profiles and pipes at twice the speed of similar saws in a comparable price bracket.

The new HBE is universal and flexible and with its extensive application spectrum, it reliably covers the wide-ranging requirements of metalworking workshops, the profile steel trade, and machine builders. The HBE series is modular in structure and with a comprehensive range of accessories, can be adjusted to suit your sawing application. The machine can be supplemented as required with infeed and outfeed roller conveyors, measuring devices and cross conveying systems, as well as NC mitre adjustment.



### HBE 321A high performance, automatic enclosed bandsaw

The HBE Dynamic series was designed to be the everyday saw due to its affordability, versatility and efficiency. The compact band saw has a multitude of leading-edge features designed to improve performance and precision, while maximising user convenience and safety.

Among the innovative range of features on the saw is the servo-driven ball screw blade feeding system and pressure sensors. This automatically provides precise, constant downfeed control and adjustment to continually optimise the cutting process. The ball screw-driven material feed gripper eliminates backlash and ensures precise material positioning and repeatability.

The HBE-321A is a durably constructed saw made of vibration-dampening grey cast

iron frame and components with cutting capacities up to 13.7" x 12.6". Its rigid and robust dual column design, unmatched speed, precision and repeatability lead to unparalleled cut quality and increased blade life.

Behringer prides itself on building the highest quality metal sawing and fabricating equipment in the world. The primary goal is to create value for their customers, by continuously striving to achieve the highest combination of speed and accuracy, combined with cost-effectiveness. All equipment design is based on achieving these primary objectives, on a dependable and long-lasting machine and in that regard Behringer is truly the benchmark.

All Behringer metal sawing equipment is manufactured in Kirchartd and Weilheim/Teck, Germany, while the structural fabricating equipment is produced in Dijon, France. The key to the high quality of the products is based on two primary criteria: firstly the research, design, and testing, that Behringer invests in the process and secondly that it controls the manufacturing process internally, with its own foundry and machining centers, to assure the highest quality and availability of materials.

With over 85 years in metal saw manufacturing, Behringer has clearly positioned itself as a technological leader in the industry. This, coupled with the synergistic manufacturing capabilities, commitment to excellence and a mindset of not taking shortcuts, keeps it on the forefront of quality.

Behringer Ltd offers a comprehensive range of Behringer and Eisele machines at its UK service centre. It can carry out competent test cuts with customer material so as to validate suitability of materials for specific applications. Behringer specialises in solutions for cutting specific metals and wherever possible will be able to recommend the most appropriate bandsaw and circular sawing solutions.

**Behringer Ltd**  
**Tel: 01296 668259**  
**Email: [info@behringerltd.co.uk](mailto:info@behringerltd.co.uk)**  
**[www.behringerltd.co.uk](http://www.behringerltd.co.uk)**



THE MECAL MC 305  
**KOSMOS**  
4 AXIS CNC  
MACHINING CENTRE



www.addisonsaws.co.uk

**Addison**  
PROVEN IN PRODUCTION

01384 264 950

For high speed machining of aluminium, steel, brass, copper and PVC materials... ideal for a diverse range of applications.

**NEW 2019-20 60 PAGE BROCHURE  
RING FOR YOUR FREE COPY**

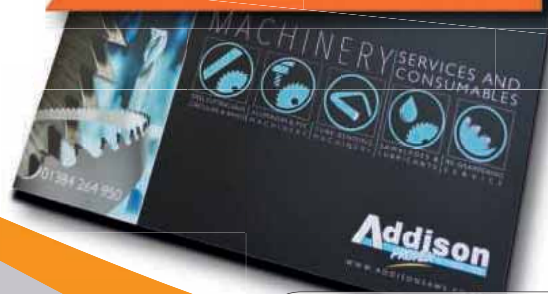

Bigger isn't always better... the EP330s is compact with the capacity, speed and ability of a bigger, more expensive machine.

**EVERISING EP 330s  
CNC TWIN COLUMN  
HIGH SPEED  
AUTOMATIC BANDSAW**

# Cutting Blades Saws

From the smallest to the largest, Accurate can cut it. With our 25 tonne lifting capacity, 2000mm diameter or 6000mm x 1000mm in a single pass cutting capacity we have the largest subcontract cutting capability in the UK.



Plate and block cutting, tube and solid bar, structurals, castings and forgings all sawn to size on heavy duty bandsaw machines. Any alloy or condition, shape or size. **If you would like to know more, give us a call.**



Amada bimetal, carbide and powdered tip bandsaw blades made to size for delivery anywhere in the UK.

Precision ground blade tips using latest tip materials give a lasting blade life and good finish.

We also supply Julia circular saw blades in HSS, coated or tipped form ground to your requirements.

**Call to discuss your requirements.**



Quality saws from Amada and Soitaab band and circular saws.

Manual, mitre, plate and gantry saws and fully automatic sawing systems capable of cutting up to 3000mm diameter. Accurate can supply a saw to suit your requirement.

**Call our sales team to discuss**



44-45 Crossgate Road  
Park Farm Industrial Estate  
Redditch  
Worcestershire  
B98 7SN

**T: 01527 527058**

**E: sales@accurate-cutting.co.uk**

**W: www.accurate-cutting.co.uk**

# Addison CNC's ramp up production for Hydro Components

Hydro Components - Bedwas recently purchased a total of four Mecal CNC machining centres from Addison to increase production of complex aluminium parts destined for state-of-the-art electric vehicles.

The Welsh company recently invested £9.6 million in the refurbishment and re-opening of its manufacturing plant based in Bedwas, adding three Mecal Kosmos 4-axis machining centres and a Mecal Geos MDT 5-axis machining centre, the first of its kind within the UK, along with the restructuring of the entire plant. Fuelling this decision was an extensive contract for the supply of aluminium body components intended for manufacturers of zero-emissions vehicles aiming to tackle pollution levels on the streets of the UK.

"At first, Hydro needed to outsource the CNC machining element as issues with their previously bought machinery meant they lacked the functionality to produce the parts themselves" recalls Mike Grogan, Addison regional sales manager. Hydro began to use a local subcontracting company operating three Mecal Kosmos machining centres, which were ideal for producing the required parts. However, it soon became apparent that bringing the operation back in-house would be more beneficial in terms of turn-around time, overall cost and allow for greater control over the manufacturing process.

After the successful installation of the Kosmos machines, Hydro's production manager at the Bedwas plant was interested in setting up a single step automated production line, eliminating the need for their additional saws. After in-depth discussions, Hydro placed an order for the new 5-axis MC 302 GEOS MDT 8.6 m CNC machining centre.

Addison Saws then flew key members of the Hydro production team out to Mecal's factory in Italy to view the machine in action. Along with seeing the factory, the management team was reassured knowing that the Mecal software could handle the bespoke programmes required for complex parts.

Leading CNC engineer Ian Freeman from Addison Saws has been instrumental in the



installation of all the Mecal machinery, which is now working to near-full capacity producing the 70 separate profiles required for one of Hydro's current contracts.

Hydro's production manager comments: "Addison have been a great help all round, from selecting the right machinery to assisting in the program writing and ensuring we get the very best out of all our machines.

They even supplied an engineer to assist us with machining centres bought elsewhere. We are very pleased with our choice; it's enabled us to tender and win several similar upcoming contracts with major names in the automotive industry".

Since installation, engineers from Hydro have flown out to Italy to receive one-on-one training from MECAL and this forms part of their strategy to ensure that the machines work to their full potential and that they have capable engineers in place who have in-depth knowledge and a full understanding of how they operate.

In excess of 130 jobs will be created over the next five years at the recently re-opened Bedwas plant and their investment is backed by Welsh Government, who were keen to invigorate the area with the prospect of new jobs and increased industrial development.

The Mecal MC 305 Kosmos machining centre is equipped to automatically machine, drill, mill, slot and prep both aluminium and steel extrusion bars. Providing immense flexibility, it is also well suited to new product development, while



its high levels of accuracy and repeatability ensure minimal waste.

For high speed machining of aluminium, steel, brass, copper and PVC materials, the 5-axis Geos can be used for machining slots, pockets, holes and custom shapes as well as end slotting, tapping, rigid tapping, drilling and flow drilling. The addition of a 400 mm sawblade enables the user to cut pieces to length before machining.

Features include: compound machining angles using both A- and C-axis; A-axis 250° rotation for working on 3 sides; C-axis 440° rotation for working profile ends; the latest HSD liquid cooled 12 kW encoded spindle for rigid tapping applications; saw blade up to 400 mm; optional angle drive unit to machine profile sides; pendular loading for seamless production; automatic tool magazine with 18 positions.

**Addison Saws Ltd**  
**Tel: 01384 264950**  
**Email: [sales@addisonsaws.co.uk](mailto:sales@addisonsaws.co.uk)**  
**[www.addisonsaws.co.uk](http://www.addisonsaws.co.uk)**



# The Revolution is here!

Spindle Revolution has opened a new state-of-the-art Spindle Repair Facility in the heart of Gloucestershire. Proudly supporting UK manufacturing, we have re-shored our business to ensure all UK customers receive unrivalled repair times coupled with our most competitive pricing.  
Spindle Revolution. Excellence as Standard.

Minimise your machine downtime with our pool of exchange spindles

12 Month Warranty\* supplied with all spindles  
\* Or equivalent 3000 working hours

All repairs are fully documented and traceable throughout the complete repair process

We have the capacity to test run all spindles and motors up to 180,000 r.p.m

Meticulous attention to detail ensures our reports give an honest appraisal of the condition of your spindle

All spindles are supplied super precision balanced, comprehensively tested and delivered ready for installation



Technically Advanced Spindle Repairs

**We repair mechanical and electro-mechanical spindles for CNC Machining Centres, Lathes, Routers, Grinders and Boring Heads.**

All makes supported inc: Diebold, DMG, Fischer, Franz Kessler, Gamfior, GMN, Makino, Okuma, Omlat, Step-Tec, Weiss and many more....

[sales@spindle-revolution.uk](mailto:sales@spindle-revolution.uk)

Call now for a free, no obligation quotation

**[www.cnc-spindle.repair](http://www.cnc-spindle.repair) 01594 368 484**

# Four-edged Powerhouse

The WTX HFDS is the  
Number 1 in solid carbide drilling

Find out more at:

[cutting.tools/en/wtx-hfds](http://cutting.tools/en/wtx-hfds)

CERATIZIT is a high-tech engineering group specialising in cutting tools and hard material solutions.

**Tooling the Future**

[www.ceratizit.com](http://www.ceratizit.com)

TEAM CUTTING TOOLS



klenk