

Does your machine tick all the boxes?

- ✓ Capacity
- ✓ Quality
- ✓ Price
- ✓ Footprint
- ✓ Performance

THE VM RANGE OF MACHINING CENTRES

We appreciate that deciding on the right machine tool is a major decision for any business. For most smart companies it's more than a question of price. You need confidence that the machine will meet all requirements for the future. The great benefit of the Hurco VM range is you have all bases covered. High quality, accurate machining, large travels, small footprint and a control that makes one-offs a breeze.



- ✓ Easy to program conversational control
- ✓ ISNC compatible - Powerful NC editor
- ✓ Simple step to 5 axis or Robot loading

CALL 01494 442222 NOW FOR MORE INFORMATION

MACHINING CENTRES

TURNING CENTRES

5 AXIS

DOUBLE COLUMN

SUPERIOR CONTROLS

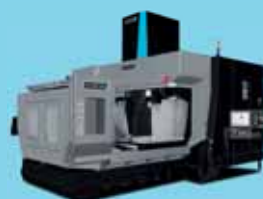

HURCO
EUROPE

12 Merlin Centre • Lancaster Road • Cressex Business Park
High Wycombe • Buckinghamshire • HP12 3TB • Tel: (01494) 442222
sales@hurco.com • service@hurco.com • www.hurco.com

DUGARD

Kitamura – unbeatable speed, accuracy and price combination from Dugard

Known worldwide for innovation, power and incredible accuracy, Kitamura's innovative range of horizontal, vertical and 5-axis machining centers have been delivering high-quality results since 1933.

And as Kitamura's exclusive UK distributor, we're now offering some of our best deals ever for a limited time.

With special deals on many of our best selling Kitamura machines, including the powerful **Mycenter range**, Kitamura machining centres are the best price and performance solution on the market.

 **KITAMURA®**



Kitamura Mycenter

Some of the most accurate machines on the market, fully automated from a single source

With solid boxways on all three axes and the feature-packed Arumatik-Mi control, Kitamura's Mycenter range of vertical machining centres are ideal for heavy-duty cutting and high-speed accuracy.

Call our sales team now on 01273 732286 or email us at
Or visit our brand new website for more information

@ sales@dugard.com
www.dugard.com

Visit our website at:
www.engineering subcontractor.com

CONTENTS

NEWS	4
MOTORSPORT REPORT	6
METAL CUTTING	8
FEATURE - AUTOMATION	14
TOOLING & WORKHOLDING	24
FEATURE - METAL MARKING	28
MEASUREMENT & INSPECTION	32
CAD/CAM	36
FEATURE - WATERJET MACHINING	40
METAL FORMING	46
WELDING	48

NEXT ISSUE FEBRUARY 2021

- MEDICAL REPORT
- 5-AXIS MACHINING
- CUTTING TOOLS
- MEASUREMENT & INSPECTION
- SAWING & CUTTING OFF
- PRESS BRAKES

Published by Roger Barber Publishing
Enterprise House, Foundry Lane, Horsham, West Sussex, RH13 5PX
Tel: 01403 266022

Publisher/Editor: John Barber - 01403 266022
Email: john@rbpublishing.co.uk

Accounts: Jackie Barber - 01403 563791

Production manager: Anna Rodrigues - 01472 210712
Email: studio@rbpublishing.co.uk

Design & Production: Roger Barber Publishing
Print: Holbrooks Printers Ltd, Portsmouth, Hampshire

Engineering Subcontractor is mailed to a controlled circulation of readers with a legitimate interest in the content. Roger Barber Publishing stores all business data securely and does not share with third parties.

No part of this publication may be reproduced without express written permission.

Hurco forecasts a growth in automation sales through 2021

2020 was a challenging year for everyone. But, while most businesses struggled to keep employees safe in the workplace, unmanned operations could continue without interruption. It would not be logical to commit to machine automation or robot loading simply to avoid the problems caused by the pandemic. However, the obvious benefits of automation have certainly been made clear.

Imagine an employee that never takes time off sick, never complains and does not even need the occasional trip to the



dentist. Then imagine that the same employee will happily work all night and all weekend and does not attract any of the additional costs of employment, such as overtime, national insurance, or pension contributions. In fact, after a modest, up-front investment, you keep them forever with no pay increases and minimal running costs, so long as you invest in the right level of quality.

The cost justification is simple, but the selection process is not. Hurco realised that they needed automation solutions for component handling and also for the handling of workholding, such as pallets or vices. The two approaches require substantially different solutions. More than one product was required to meet all customer needs.

The ProCobot range of collaborative robots specialises in component handling. This is a relatively low-cost, plug and play solution that better suits runs of 20 or more. It uses an app that opens directly on the Hurco Max5 control, making programming of jobs and movement between machines as easy and as simple as possible.

The Erowa systems offer pallet handling capability. The most popular automation solution provided on Hurco machines worldwide is the Robot Compact 80 with several installations in the UK. The benefit of this system is the ability to automate one-offs, or a variety of similar components. Also, one pallet system can feed two machines. Compact design and exceptional reliability have established Erowa as a primary partner in Hurco's future plans.

The third option is a collaboration between Hurco and BMO. This option fills the middle ground between ProCobots and Erowa and allows component or pallet handling, depending upon the option selected. Trays can be used for component stacking and adjustable grippers used for different sized parts.

Hurco Europe Ltd Tel: 01494 442222
Email: sales@hurco.co.uk www.hurco.co.uk

Spot the difference

They say that a year is a long time in politics but, in 40 years in trade and technical publishing, the changes are far more apparent

By Roger Barber

After a few years in telesales and in the field with Industrial Exchange & Mart, I joined Production Equipment Digest in 1984 as a sales executive.

1984 was momentous in other ways: Margaret Thatcher was Prime Minister and Ronald Reagan won a second term as US president. It was also the year of the Miners' Strike, Band Aid and the murder of Indira Gandhi.

Against this backdrop, Britain was actually doing rather well and the machine tool and engineering sectors were booming. Trade & technical magazines were sailing along nicely and life in advertising sales couldn't have been better. Business lunches and client entertainment were paramount in generating advertising and if you worked hard the rewards were amazing.

It was therefore something of a shock when, after purchasing the AGB Pergamon Group of which PED was a part and then merged with Maxwell Business Communications, Robert Maxwell died on his luxury yacht in 1991. I was then advertisement director of PED at the time and recall the moment when we received the call announcing his demise. Within a couple of years, the empire collapsed, PED was folded and we were all made redundant.

In the ten years or so after this, I worked freelance and launched Essentials for



Industry with Barry Smith of Colby Publications. This was the era when colour separations were king, even though the advances in the printing process rendered them unnecessary. Interestingly, there are still publishers charging for these today!

In 2003, I identified a need in the market for a production grinding and surface finishing magazine and launched Grinding & Surface Finishing. Now in its 18th year, it has established a position as the leading magazine in its field, supported by a raft of leading machine tool companies and major players in the production grinding, blast cleaning, honing, deburring and component cleaning sectors.

A year later, armed with research carried out in the engineering market, I decided to launch a magazine mailed exclusively to subcontractors in the UK and Ireland. Comprising companies with 10 employees or less that made 80 percent of purchases of machine tools and ancillary equipment, Engineering Subcontractor is unique as it specifically targets these readers rather than relying on a "catch all" approach.

Over the past few years, along with other publishers, we have been propelled into the world of hits, traffic and webinars that now dominate our world. However, even a leading online platform provider has shown the continuing importance of printed magazines by launching its own magazine.

Feedback from our readers shows that they still want magazines to read that are informative and well designed to guide them to what they should be looking at online. They tell us they simply don't have time to trawl the internet aimlessly to find what they don't even know they need. Despite the challenges that it had brought, it has provided a wake-up call to publishers to reassess our priorities for the readers.

So what makes our magazines different? Firstly, they are easy to read with clearly defined features and sections. Overall, we also publish more editorial than other magazines in the market. Less advertising of course makes it harder, but we still want to maintain issue sizes to maintain the editorial content. We also edit press releases to fit



our own editorial style. Contact details, i.e. company name, telephone number, email and web address are included for readers to follow up their interest.

Finally, I would like to thank all the companies that have supported us over the years and continue to do so. I am confident that we will meet the challenges full on and enable our advertisers and readers to be successful.



New president for the MTA as first virtual AGM is held

December 2020 saw members of the Manufacturing Technologies Association (MTA) meet online for its first ever virtual AGM. As part of this meeting, it welcomed a new president Andy Hodgson, strategic lead for digitalisation at Siemens. Andy Hodgson has played an active role in the MTA for many years as a board member and has served as the technical committee chairman for that last two years, stepping down to take on this new role.

He will serve a two-year term as president of the association. He has a wealth of experience in the manufacturing technologies sector as well as first-hand experience of the acceleration of digitalisation within the industry. He takes over the office from Marcus Burton MBE, who was warmly thanked by the meeting.

Andy Hodgson said: "Marcus Burton's presidency will be a hard act to follow and his leadership and foresight has been, and still is, critical to the continued existence of the association. It is a great honour to be appointed as president of the MTA and I hope that I can build upon the successes we

have shared and bring the projects we have started to fruition. I look forward during my presidency to steering the association, supported by the board, through the troubled waters that still lie ahead with a pandemic still upon us and Brexit just around the corner."

James Selka, CEO of the MTA said: "We are delighted to welcome Andy Hodgson as president of the association. His strength of bridging the gap between machine tool control and representing Siemens for industry 4.0 in the UK, make him an ideal representative of our rapidly evolving industry."

The MTA exists to promote the interests and be the voice of the manufacturing technologies sector in the UK. The Manufacturing Technologies Association is the UK's trade association for companies in the manufacturing technology sector.

MTA members design, manufacture and supply the advanced machinery, equipment and intellectual property that enable the creation of the products we rely on from day to day and that drive our economy.



Established in 1919, the MTA has been at the core of the UK's engineering-based manufacturing economy for over a century.

MTA
Tel: 020 72986400
Email: info@mta.org.uk
www.mta.org.uk

New managing director for Addison Saws

In December, Addison Saws Ltd, a leading Midlands-based metal cutting equipment supplier appointed a new MD. Former UK sales director Chris Wilson has been selected for this pivotal role and charged with taking the 65-year-old company forward after a brief time serving as acting MD this summer. Stepping into the role of UK sales manager is Darren Creasey, who some may know as the area sales manager for the South East.

Chris Wilson has been with Addison Saws for 15 years, starting his career as an office-based sales representative and holding several positions within the company since, including sales manager and most recently UK sales director. He steadily formed strong customer and supplier relationships along the way, helping to shape Addison Saws as it is known now. This new title role has been earned after working many years under previous MD, Gary Knight's guidance, heading up UK sales and dealing with all aspects of the business, and with the company vision of supporting UK

manufacturing always driving decision making forward.

Although coming in at an uncertain time for industry in general, with COVID-19 creating waves and BREXIT looming, this is a nod to the future for the company. Suppliers, dealers, and customers continue to put their faith in Chris Wilson and Addison Saws to keep them in production and meeting their own deadlines, evident from a very healthy order book regardless of the current climate.

He says: "It's an honour to be entrusted with leading a business with history such as Addison's and our company values will continue to push us through this year and hopefully many more."

Darren Creasey has been working at Addison Saws for almost nine years, with a steady focus on generating and handling all aspects of machine sales in the South East of the UK. Having built an enviable sales record within that time, he will continue to maintain sales duties with his area going forward, as well as supporting Chris Wilson with the



management of the department.

It would appear that Gary Knight is not quite ready to hang his boots up yet, gladly taking on the role of Chairman and to be on hand when the need arises to work on the specialist or bespoke machinery side of Addison Saws Ltd.

Addison Saws Ltd
Tel: 01384 264950
Email: sales@addisonsaws.co.uk
www.addisonsaws.co.uk

Zircotec increase capacity ten-fold following £2.5m investment

Automotive and motorsports heat management specialists Zircotec, based near Oxford, is set to grow significantly this year, with a ten-fold increase in capacity. This follows a £2.5 million investment into much larger premises and new equipment. The workforce is also increasing to meet the exceptional demand. This comes after having to overcome some unexpected hurdles over the last 18 months.

The company is an expert in plasma-spray processing and thermal barrier solutions. It develops and produces industry leading high-performance surface coatings and finishes and bespoke heat shielding solutions. It works with most F1 teams and many other motorsport formulas, as well as several supercar and other performance car OEMs.

Zircotec now plans to build and grow business established in other sectors, such as electric and hybrid vehicles, oil and gas, marine, power generation and aerospace, which the company believe offers excellent growth opportunities. These industries have stringent emissions targets and heat management requirements and Zircotec's technology can provide a solution to manage heat, without adding excessive weight; key characteristics highly sought in these industries.

Sales director Graeme Barette says: "The new and expanded facility means we can actively develop other sectors, where previously we were constrained by our capacity. Our success to date has largely been in automotive and motorsport, however we know our technology is valuable to many other industries too, particularly in the hybrid and electric vehicle markets. We know that lightweighting and heat management are critical issues in this industry and Zircotec has a solution that can solve these heat management issues."

Zircotec offers a range of industry coatings with different performance characteristics, ideal for many different applications. This includes the plasma applied ceramic coatings, a flexible heat shield material, carbon composite coatings, anti-wear coatings and ceramic fabrications, as well as leading heat shielding solutions.

The company has also developed a



conductive ceramic battery coating that provides RFI shielding with a weight saving of up to 4 kg per m² compared to aluminum. This enables manufacturers to use carbon or plastic composite battery casings for hybrid and electric vehicles rather than the much heavier aluminum solution.

In July 2019, a fire destroyed the previous Zircotec home. A disaster recovery plan was put in place and within days Zircotec were back up and running in a temporary facility nearby. The new permanent home was found, just 300 yards from the old facility. This was a huge 20,000 sq ft location, compared to the previous site, which was only 9,000 sq ft.

By October 2019, following extensive adaptations, the company relocated to the new building. The facility was fully operational by the end of the year.

Graeme Barette is extremely proud of the company's efforts in recent months: "Back in July 2019 we were all devastated and the whole workforce really pulled together. By the end of the year we were in this much bigger and better facility, ready for expansion, to meet anticipated growth then COVID-19 happened. You couldn't make it up. Thankfully the workforce is back, with even more staff than before and we're still recruiting to increase our headcount by almost a fifth because the demand is there. This has been an exhausting but rewarding

period for all of us and we're really excited about the future."

The new purpose-designed building is set to accommodate planned growth. The amount of specialist equipment has in some cases, trebled. This includes the addition of a bespoke heat shield facility. A team of specialists can create unique heat shield solutions to meet a customer's specific requirements.

Some of this specialist equipment has also been automated. Previously there was one automated booth used for plasma spraying. This is being increased to five, significantly increasing the available capacity, to meet growing demand. Automation will reduce downtime, delivering extremely consistent results at the same time as massively increasing production output. This is in line with OEM requirements and mass production programmes.

The focus today is very much on continued innovation and Zircotec has a five-year plan in place to grow the company by 400 percent. This will be achieved by moving into new markets and an ongoing investment in the skilled workforce.

Zircotec Ltd
Tel: 01235 546050
Email: enquiries@zircotec.com
www.zircotec.com

'Wet' and 'dry' 5-axis machining of composite components

Founded in 2003 jointly by John Biddlecombe and Simon Kingdon-Butcher, Global Technologies Racing (GTR) is a leading manufacturer of laminated carbon fibre components for the motorsport sector in the UK, supplying most of the Formula 1 teams.

Metallic materials are also machined and the components produced are to be found in all parts of a race car: chassis, transmission and engine. GTR caters for everything from concept and design through patterns and moulds to complete assemblies.

Prior to starting the subcontract machining firm, the two directors owned G Force, which designed and built racing cars for various motorsport series including IndyCar, Formula Nippon and Le Mans Prototype sports cars. Another notable success was the construction of Thrust SSC, which holds the current land speed record of 763 mph set on 15th October 1997.

Over the last decade and a half, GTR has become so successful that the constantly rising demand on its machine shop in Easthampnett, West Sussex, meant that it needed to expand into a second facility in

nearby Bognor Regis at the beginning of 2018. Shortly after moving in, a pair of Hermle C 400 machining centres was ordered from UK agent Kingsbury to boost the contract machinist's capability for 5-axis processing.

The first, with a coolant tank for 'wet' machining and an additional 50-pocket tool magazine to supplement the standard 38 cutters, was delivered in mid-2018. It was followed in February 2019 by a second model equipped with dust extraction for 'dry' machining of composite materials without coolant. Both machines have a trunnion-mounted table that provides the fourth and fifth CNC axes.

When GTR moved into its new Bognor Regis premises, in so doing it took over another subcontractor supplying the motorsport sector and inherited a number of machine tools, one of which was a nine-year-old Hermle B 300 5-axis machining centre.

Simon Kingdon-Butcher says: "The performance and reliability of this machine played a part in our decision to purchase two new models of the same make, despite



having used 5-axis machining centres from other suppliers for many years. Hermle machines have a good reputation in the market and our machine shop manager, Martin Sammut, was familiar with the brand.

"Kingsbury's approachability and reputation for providing good training, technical support and after-sales service clinched our decision to purchase from them."

Kingsbury

Tel: 023 9258 0371

Email: solutions@kingsburyuk.com

www.kingsburyuk.com

The 5-axis machine you've always wanted is now available

GENOS M460V-5AX

When customers asked us to bring an affordable, high-performance 5-axis machine to market, we accepted the challenge. The result is our new GENOS M460V-5AX, a next-generation vertical machining centre that offers unrivalled accuracy and productivity at an affordable price point.

At Okuma, your feedback becomes our mission.

Contact

NCMT Limited
Tel 020 8398 4277 Fax 020 8398 3631



www.ncmt.co.uk



OPEN POSSIBILITIES



Fixed-head turning up to 40 percent faster and tool life doubled on sliding-head lathe

In August 2020, Merseyside subcontractor Bryken took delivery of its sixth Miyano BNE-51MSY turn-mill centre, having bought its first as recently as June 2018. Operations director Phillip Taylor says that regular investment in the new plant is key to thriving in a competitive global marketplace and he makes sure that no machine tool stays on the shop floor for more than 10 years. The company, which has 95 employees and a £10 million annual turnover, derives 40 percent of its business from the oil and gas industry and is also a major supplier to the high-voltage power sector, amongst others.

Citizen Machinery UK, which supplied the fixed-head Miyanos, is also the source of four Cincom CNC sliding-head lathes currently on site, which have been in use at the Prescott factory since the mid-90s. A dozen older models, which took over from six times as many cam autos, have all now been replaced. It leaves three 32 mm capacity Cincom sliders installed since 2014 and a more recent 20 mm capacity model that uses Citizen's proprietary LfV chipbreaking technology.

Phillip Taylor, son of one of the company founders, runs the subcontracting business together with his brother Stewart and sister Natalie Lund. He explains: "90 percent of our turnover comes from producing precision turned parts, many of which



require a lot of prismatic machining as well, so choice of turn-mill centre is crucial to our success.

"We started to upgrade our fixed-head lathes by replacing them with Miyanos in 2018 in response to an upturn in demand, which gathered pace at the beginning of this year when we bought three more BNE-51MSYs in the space of two months. The 51 mm bar capacity, twin-spindle turning centre with its two 12-station live turrets, the upper one with a Y-axis, is ideal for our needs.

"It is highly efficient at balanced machining of complex routines at both spindles, so we can take chunks out of cycle times, which are between 20 and 40 percent faster than on previous lathes. It meets the increasing demand for the supply of high added value parts at competitive prices."

One reason for the lathe's impressive speed is Citizen's superimposition control technology, which allows the sub spindle to track the upper turret for cutting reverse-end features while the same turret is performing front-end operations on bar at the main spindle. If the lower turret is operational at the same time, three tools are in cut simultaneously, delivering the performance of a triple-turret lathe for a significantly lower capital outlay.

Over the years, market forces have dictated a move at Bryken towards more fixed-head turning for the production of larger diameter, complex components, the simpler work having largely disappeared overseas. Nevertheless, nearly one-third of the lathes on-site are still of the sliding-head variety. The four Citizen Cincom models are the most recently installed, three M32-VIII lathes and an L20-XIILFV, the cardinal

numbers representing maximum bar diameter.

The latter machine, installed in May 2018, was bought to produce sub-sea oil and gas components from tough materials such as Monel, Inconel, titanium alloy and 440C stainless steel. These metals produce stringy swarf that benefit greatly from the low frequency vibration (LFV) functionality built into the operating system of the Mitsubishi control.

Low frequency vibration technology has started to be rolled out across the Miyano fixed-head lathe range with the introduction of the BNA-42GTylfV and Phillip Taylor is keeping a close eye on this development. He pointed out that subcontractors rarely know the orders that will be coming in next and which materials they will be asked to machine. As LFV is not a pecking macro that tends to prematurely wear out tools, but is integral within the control system, having this built-in chipbreaking capability is of great benefit when machining stainless steels, copper and plastics as well as the nickel and titanium alloys.

Phillip Taylor concludes: "We source a lot of lathes from Citizen because they have a wide range of machines that use advanced technology. We also receive good support from them, especially the applications engineering and training they provide."

Citizen Machinery UK Ltd

Tel: 01923 691500

Email: sales@citizenmachinery.co.uk

www.citizenmachinery.co.uk



5-axis travelling-column machining centre for large workpieces

High precision 5-axis machining of components up to 2,300 mm long may be carried out productively on the new DMF 200|8 travelling-column machining centre from DMG MORI.

Having a rigid table measuring 2,300 x 850 mm and travels of 2,000 x 800 x 850 mm, the DMF 200|8 offers users in the aerospace and mould making industries, for example, scope to machine long components up to the maximum table load of 2,000 kg. Rapid traverse in the linear axes is 50 m/min as standard, but with an optional linear drive in the X-axis it reaches 80 m/min. Holistic cooling throughout the machine delivers long-term accuracy and tight tolerances.

The B-axis milling head with 6,000 Nm maximum clamping torque offers a swivel range of ± 120 degrees for flexible 5-axis machining. A 15,000 rpm speedMASTER spindle is standard, while an extensive choice of other modular spindles is offered including a 200 Nm high-torque version and a 20,000 rpm high-speed version. All are covered by a 36-month warranty, regardless of running hours.

The machine is equipped with a Siemens control and the latest version of DMG MORI's proprietary APP-based user interface, CELOS. So users are well equipped for digitalised production and automation, for example by the attachment of the manufacturer's PH Cell automatic pallet changer.

During the development of the DMF 200|8, the working area was optimised by the innovative tool change, which takes place behind the table for fast, safe, collision-free cutter exchange, so the entire clamping surface is available for use. Compared to the predecessor model, the working volume is over 50 percent larger, creating new possibilities for machining complex components. The ability to employ 400 mm long tools is said to be a unique selling point in this machine class.

DMG MORI claims that a strong argument for investing in its travelling column machines has always been their stability, so the manufacturer has specifically considered



this area. The DMF 200|8 has been designed in such a way that the cantilevered Y-axis has consistent rigidity over the entire traverse. Three linear guideways in the X-axis reinforce the stability of the machine and create the necessary basis for highly precise and productive machining. Even with the Y-axis slideway fully extended, maximum spindle power can be applied for machining.

DMG MORI UK Ltd
Tel: 0247 651 6120
Email: steve.finn@dmgmori.com
www.dmgmori.com

Taking The Industry By Storm

The latest addition to the Colchester product range is the **Storm Vertical Machining Centre**.

- Available in a wide range of linear and boxway models
- Rigorous testing including laser interferometer and ball bar
- High specification including Dual contact Big Plus Spindle as standard

- X-axis stroke 500–1600mm
- Spindle speed up to 20000rpm
- Spindle power 7.5–18.5kW
- ATC capacity 20 - 24 tools (BT40)

CONTACT US ON +44 (0) 1924 415000
OR INFO@COLCHESTER.CO.UK

LOW RATE FINANCE OPTIONS AVAILABLE



Pair of high-speed machining centres duplicated after 20 years

Rapid Design Manufacturing Solutions (RDMS), a leading manufacturer of plastic injection production and rapid mould tools, has invested in a second pair of ultra-high-precision, 3-axis, Vertical-Spindle Machining Centres (VMCs) from the German manufacturer, Roeders. The machines were supplied to the toolmaker's Oldham factory in autumn 2020 by sole UK agent Hurco Europe.

Established in 1998 and run by co-owners Neil Richardson and Paul Ryan, RDMS works closely with its customers to provide high-end, multi cavity tools to a maximum of two tonnes in weight in short lead-times at competitive prices for producing the most exacting plastic components. Some of the more challenging applications involve in-mould labelling and multi-shot tool production.

Medical work features significantly, including providing assistance to suppliers of hospital and laboratory equipment in the current pandemic. In addition, the firm manufactures injection moulds for producing interior trim that ends up in, for example, Mercedes, BMW, Audi, Porsche, JLR and Nissan cars.

A particular specialism at Oldham is the machining of two-shot tooling, used to produce complex parts from two different materials, without the need for assembly, by overmoulding plastic around a preformed plastic or metal insert, often in high volumes. Extreme accuracy and repeatability of machining is required when producing this type of tool and is the reason that RDMS selected Roeders machining centres right from the start.

To increase capacity, both in terms of throughput and workpiece size, a couple of years later the toolmaker purchased a larger, stand-alone Roeders RP800 with 800 x 600 x 400 mm working volume,



30,000 rpm high-torque spindle and up to 60 m/min feed rates.

Even today, a polisher only needs to go over the machining marks on a mould produced on either machine; there is no need to revise the mould's form. Customers are shown a part-to-CAD comparison to prove the fidelity of the machined shape to the design.

The feature of Roeders equipment that originally clinched its selection by the toolmaker, after four different machining centres had been trialled, was the ability of the machines to scan across the shut face, down into the mould features and then back up to the shut face in one continuous path, producing razor sharp edges at the transitions.

According to Neil Richardson, if lower quality machines try to achieve a similar result, edge quality is lower and definition is lost in the moulded part. Modern inspection techniques can easily identify such imperfections. The solution is to machine the shut face first in its entirety and then the mould features, but that takes longer, requires more job management and lowers profitability.

To cope with an increasing order book and reinstate the ultra-high milling accuracy originally obtained with the 20-year-old



Roeders machines, the two early models have now been supplemented by a pair of more modern, 3-axis, high-speed machining centres from the same German manufacturer. It leaves the 600p machine free to produce nearly all of the graphite electrodes in use in the factory, as well as mould tools. The RP800 also continues to be used.

The new RXP500 has a 500 x 455 x 240 mm machining envelope and 60,000 rpm spindle, while the new RXP801 offers 800 x 635 x 400 mm and 42,000 rpm. Both machines have spindle growth compensation and the former is fitted out with an interface for the future addition of an Erowa 120-pallet cell. For now, however, the new machining centres have been placed side by side and the manual handling device and CMM have been relocated to serve both machines.

All machining centres on-site are vertical-spindle models from Hurco, not only the Roeders but also several own-brand, 3-axis models fitted with the WinMax twin-screen control system. In addition to two Hurco BMC30s and the same number of BMC2416s, there is a pair of VMX42i machining centres, the second of which was installed in 2018.

They are all used for manufacturing bolsters, ejector plates, back plates and other less high-precision work. However, it is notable that the latest Hurco VMX42i has linear scales rather than rotary encoder feedback of axis position to the control, making it sufficiently accurate for finish-machining of dies.

Hurco Europe Ltd
Tel: 01494 442222
Email: sales@hurco.co.uk
www.hurco.co.uk



Rapid response from XYZ Machine Tools helps Shield Marquees meet COVID demand

At the start of this pandemic the focus was on ventilators, but as things developed testing became the priority of Government. Step forward Atherstone-based Shield Marquee Manufacturing. While its usual customer base, the hospitality industry, continues to face strict restrictions, Shield Marquees became part of the marquee hire industry's National Emergency Testing Stations Network (NETS).

Working with the Government, NETS has been central in supplying the network of test centres for COVID-19 with temporary structures. The demand for a quick response, however, placed significant pressure on Shield Marquee's manufacturing capability.



"With every structure containing multiple machined components such as leg and ridge knuckles, we found that our existing machine capacity was limited and the volumes we were asked to produce were leading to backlogs, which were not acceptable. We therefore needed to improve that and very quickly," says Matthew Faizey, director of Shield Marquees. While speed was crucial he was also cautious and carried out due diligence online of a select group of machine tool suppliers, with XYZ Machine Tools coming out on top: "If I'm going to spend a significant amount of money, I want to do my research and check on a supplier's viability, history, reputation and ability to support my business. XYZ Machine Tools impressed in all respects. In particular, was the knowledge that we can get the support in terms of service and programming very quickly as we can't afford for the machine to be down for any length of time."

With that reassurance and with time ticking away he contacted XYZ Machine Tools early on a Friday morning and by lunchtime the order was placed and paid for. The following Tuesday the machine, an XYZ 1100 LR vertical machining centre, was delivered, commissioned and ready for production.

Matthew Faizey concludes: "We are supplying between 20 and 30 testing sites per week and the associated volume of parts meant we had to improve efficiency. The XYZ 1000LR is so much faster than our previous machine, allowing us to produce hundreds of parts/hour and it also gives us much greater versatility to machine variations of those parts if required. The speed at which XYZ Machine Tools was able to respond to our requirements has enabled us to keep up with demand on this vital project."

XYZ Machine Tools
Tel: 01823 674200
Email: nigel.atherton@xyzmachinetools.com
www.xyzmachinetools.com



THE AJAX SUPER MINI MILL



Ajax Proton AJPR400 SUPER MINI MACHINING CENTRE SIEMENS CNC Control

Table 600 x 210 mm
 X = 365 mm Y = 260 mm Z = 455 mm
 8 ATC with options of 10 or 12
 415V 3ph or 240V 1ph

£19,950.00
 + VAT

Ajax Machine Tools International
Tel: +44 (0)1590 676000
sales@ajax-mach.co.uk
www.ajax-mach.co.uk

Next generation compact 5-axis vertical machining centre

Yamazaki Mazak has unveiled a new high-accuracy simultaneous 5-axis vertical machining centre, the VARIAXIS C-600, suitable for a wide range of sectors, including the aerospace and automotive markets.

The C-600, which is the successor machine to the highly successful VARIAXIS j-600/5X, is being marketed at a highly attractive price point to provide a high performance and cost-effective 5-axis solution.

The VARIAXIS C-600 is characterised by its highly agile performance, with no compromise on rigidity. The compact machine, capable of machining workpieces up to Ø730 mm x H450 mm and 500 kg in weight, has been designed with a large machining envelope and a high-rigidity structure featuring a Ø600 mm fully supported trunnion table with roller gear cam on the B and C axes. Exceptional high-speed performance is delivered with 42 m/min rapid traverse rates in the X, Y and Z axes and a chip-to-chip time of just 4.5 seconds to reduce non-cutting time for faster cycle times.

Most importantly, the new VARIAXIS comes with a class-leading range of specification options, enabling machine users to configure the C-600 to match their specific application.

The machine's high-rigidity spindle can perform heavy-duty cutting of steel, as well as the high-speed machining of other non-ferrous materials such as aluminium, as it can be configured with four different spindle options. These range from a 12,000 rpm standard spindle, up to 15,000 rpm high-torque option, or 18,000 rpm high-speed and 20,000 rpm high-power spindles. In addition, the new VARIAXIS features a 30-tool magazine as standard, complete with double arm automatic tool changer which can drastically reduce chip-to-chip times. Alongside this standard specification, 60, 90 and 120 tool magazine options also available.

The C-600 also employs Mazak's SmoothAi Spindle function, featuring AI adaptive control, patent pending, that suppresses milling spindle chatter by intelligently adjusting cutting technology



The new Yamazaki Mazak VARIAXIS C-600 simultaneous 5-axis vertical machining centre

based on feedback from sensors built into the machine.

The modularity of the C-600 also extends to the variety of coolant packages that are available for different applications up to 70 bar pressure. Dedicated iron, aluminium and composite and casting machining packages are also available as options.

As well as offering excellent operator access and ergonomics, the VARIAXIS C-600 has been designed to integrate easily with a range of automation solutions, such as MPP and PALLETECH. Optional extras such as a side loading door and preparation for hydraulic and pneumatic fixture interfaces are also available to support bespoke automation projects with articulated robots. Integration of automation is further enhanced with the new Smooth RCC, Robot Cell Controller, adding advanced capabilities, such as tool and fixture capability check, tool set up and fixture set up, while the Robot Setup Assist enables efficient programming of the robot in the same co-ordinate system as the machine.

The latest VARIAXIS is equipped with SmoothAi, Mazak's new artificial intelligence control, which has in-built learning capability to continually improve machine performance. SMOOTH MACHINING CONFIGURATION PLUS allows operators to easily adjust features including cycle time, finished surface and machined shape on the CNC display

according to material requirements. This is especially effective for complex workpieces with contours defined in small program increments. Specific settings can be saved and stored to allow them to be easily used for future cycles.

The Smooth Project Manager also allows for easy management of data required to execute machining programs such as tool data, fixtures, coordinates, parameters and workpiece 3D models. Further machining accuracy is guaranteed by the new Ai Thermal Shield function, which uses algorithms to automatically determine the volume of compensation needed according to changes in temperature.

Yamazaki Mazak was established in 1919 and has been contributing to the development of the machine tool industry as a leading global company. Yamazaki Mazak manufactures not only advanced machine tools such as multi-tasking centres, CNC turning centres, machining centres and laser processing machines but also automation systems, supporting global manufacturing by providing exceptional productivity and versatility.

Yamazaki Mazak UK Ltd
Tel: 01905 755755
Email: sales@mazak.co.uk
www.mazakeu.co.uk

Grayline turns to Dugard

Founded only five years ago, Grayline Engineering Ltd is a subcontract machine shop located in Woodbridge that typically reflects the general subcontract sector, manufacturing 'anything and everything' according to managing director Graham Chattenton.

The majority of work undertaken by the Suffolk company generally comprises of small dimension batch and production runs of turned parts with a mix of larger parts in small quantities. The plant list at the company includes several machining centres, sliding head turning centres and fixed head lathes. Central to the company's growth is a strategy to invest in machine tools from machine tool specialists Dugard.

When asked why the company started purchasing machine tools from Dugard, Graham Chattenton said: "I had worked with Dugard machines before when I worked at other companies and they have always been helpful and I have dealt with them for many years. If there has ever been a service issue or a problem with the machines, Dugard has stepped up to the

mark and I have always been really happy with the results. When it comes to other machine tool suppliers, you don't always get the answers you want. So, at this company, buying Dugard has been a 'no-brainer' for me."

It is for this reason that, when Grayline was set up, it invested in two Dugard 32 machines. As Dugard's previous sliding headstock CNC offering with a twin spindle, twin-turret Y-axis configuration with 11 driven tools and nine turning tools, the machines have performed impeccably. Despite the Dugard 32 machines performing with distinction at Grayline, as they do for Dugard customers nationwide, the Brighton-based machine-tool industry leaders recently added the Hanwha range of high-performance sliding head lathes with guide bush capability and bar capacity from 6 mm up to 45 mm. Compared to the previous Dugard 32 series, the Hanwha machines are a leap in performance, productivity, capability and technology, all whilst retaining a cost-effective price point that is built upon the foundation of an



extremely robust machine platform. When it came to investing in additional turning capacity to complement the company's current Dugard 32 sliding headstock machines, this small subcontractor naturally turned to Dugard once again.

The majority of the machines on the shop floor are now Dugard as Graham Chattenton concludes: "The Dugard machines have been brilliant and I can't knock the company in any way."

C Dugard Ltd
Tel: 01273 732286
Email: sales@dugard.com
www.dugard.com

The next big thing in small parts production

Mills CNC, the exclusive distributor of Doosan machine tools in the UK and Ireland, has announced that, from Spring 2021, it will be introducing a new range of 10" chuck Lynx lathes, with integrated Y axes, into the market.

There are two models in the new range: the Lynx 2600Y, Y-axis model, with the Lynx 2600SY, Y-axis and sub-spindle model.

As one would expect from new Doosan Lynx lathes series the two models, in addition to their compact footprints, deliver best-in-class speed, accuracy and flexibility.

Both models share many of the advanced technology features and performance attributes of the highly-successful and popular 6/8" chuck Lynx 2100 series of lathes first introduced by Mills in the UK and Ireland a couple of years ago but provide small component manufacturers with larger turning diameters, 380 mm, longer turning lengths, 610 mm and more powerful spindle capabilities, 18.5 kW/3,500 rpm.

Tony Dale, Mills CNC's technical director, says: "The new Lynx 2600Y and Lynx 2600SY



lathes fill a gap in the market, identified by Doosan, for flexible, larger-capacity 10" chuck/81mm bar diameter lathes with Y axes. We will be introducing the new models into the UK and Irish markets from February 2021."

The new Lynx lathes are equipped with powerful 18.5 kW/3, 500 rpm spindles which, combined with their highly rigid and low vibration design and build, ensure high-accuracies, repeatability's and surface finishes; even during heavy-duty and continuous cutting operations.

Both machines are driven tool models and

their Base Mounted Turret (BMT) design and configuration improves rigidity which, in turn, helps deliver increased productivity and process reliability.

The new Lynx lathes also have a 105 mm Y-axis capability, +/- 52.5 mm, which makes them more versatile and enables manufacturers to machine complex precision parts faster and in fewer setups.

The lathes are supplied with the new Fanuc Oi-TF Plus control and features an innovative, sophisticated and user-friendly iHMI system with an intuitive, 15" touchscreen.

The iHMI enables users to have quick and complete control over all machine operations as well as the ability to monitor machine performance and respond to changing situations and demands both efficiently and effectively.

Mills CNC Ltd
Tel: 01926 736736
Email: sales@millsnc.co.uk
www.millsnc.co.uk

Ergonomic mould change in a limited space

Vehicle components manufacturer ElringKlinger, headquartered in Dettingen an der Erms, Germany, includes high-performance, lightweight plastic products such as oil pans and cam covers in the product portfolio it supplies to the global automotive industry. Tobias Gerst, production engineer responsible for capital equipment procurement and process planning says: "Over the last few years we have grown steadily and are running out of space for our production equipment, so we are sometimes faced with very cramped conditions."

Space is particularly limited where two automated injection moulding machines are operated over three shifts. They are located in an enclosure and mould exchange can only be carried out by entering a comparatively narrow, low door.

The two machines, which are positioned at an angle of about 120 degrees to each other, require a mould change every eight to nine days. As there is no overhead crane in the factory, the machines cannot be loaded from above. Instead, until recently operators used one of a number of standard transport carts.

Directly in front of one machine there is hardly any space for manoeuvring a cart, however, so previously mould change was challenging and physically exhausting. That has changed with the arrival of a compact transport cart supplied by German manufacturer, Roemheld, Hilchenbach, whose subsidiary in Hitchin supplies similar equipment into the UK market.



Tobias Gerst adds: "Our existing carts were either unsuitable for heavy moulds or too large for the limited space available. As a result we had to manoeuvre them in awkward spaces and still could not quite reach one of the machines.

"Therefore the machine had to be approached from the side instead, but this meant that the mould had to be pushed crosswise to roller bars on the changing cart. A lot of effort was required before the mould was finally in the right place."

So two years ago, he looked for an alternative that suited the special requirements better. The steel moulds used on the two machines weigh up to one tonne and have a maximum height of 400 mm, while the base varies between 300 mm x 300 mm and 550 mm x 500 mm. The new changing cart had to be able to carry all moulds sizes and still fit through the enclosure's narrow door.

He was looking for a system where moulds could be transferred in different directions so that the operator could access both injection moulding machines optimally. One of them is located to the right of the enclosure entrance and the other is positioned opposite. The operator can drive in a straight line, load and unload the cart either from the right side or from the front and reverse out.

An internet search led Gerst to Roemheld's workholding and die changing technology. One of its carts, RWA 1600, is characterised by a compact design, an electro-hydraulic lifting platform and a shuttle table equipped with hydraulically actuated ball bars. The cart is also able to be customised to meet specific requirements.

With ball bars set into the support surface of the table, dies can easily be moved manually in any direction. A special safety mechanism ensures that during mould transportation the ball inserts are lowered into the table surface so the die is prevented



from moving. Removable front and side bars provide additional safety.

As standard, Roemheld offers three versions of the 1,600 kg capacity cart with either four, six or eight ball bars. After detailed consultation, however, Gerst suggested to ElringKlinger a special version with nine bars. It ensures that even the smallest moulds used by the manufacturer are securely supported by at least two bars.

The engineer also opted for a smaller table, 850 mm wide by 750 mm deep instead of the standard size of 1,150 mm by 800 mm. The former is sufficient to accommodate all the moulds used at ElringKlinger while at the same time allowing the operator to access the narrow passages without difficulty. The cart has also been adapted to suit the low door lintel by shortening its mast by 10 cm to 190 cm.

Roemheld UK Ltd
Tel: 01462 459052
Email: terry@roemheld.co.uk
www.roemheld.co.uk

Lights out, silent feeding?

The answer's **YES**

Short, Long,
Fixed Head, Sliding Head,
Multi-Spindle,
Special Purpose,
Industry 4.0, UK Based
Service and Support.



IEMCA from 1st MTA

For all your Barfeed requirements.

1st MTA. The UK's leading machining
accessory supplier.

Email: enquiries@1mta.com Freephone: 0800 783 0510

Fax: 0800 783 0517 www.1mta.com

1st
MTA
MACHINE TOOL ACCESSORIES

1st MTA says "Don't wait to automate"

One of the repercussions of COVID-19 has been a widespread discussion about bringing more manufacturing back to the UK. But is reshoring large amounts of production realistic in the short term, or is industry unprepared to cope with the higher demand for making parts cost-effectively and profitably?

Workholding and automation specialist 1st Machine Tool Accessories thinks that UK manufacturing industry is potentially ready but needs to adopt a higher level of automation to achieve economical production through some level of unattended operation of machine tools. However, the company stresses that big investment in expensive robotics is not a prerequisite for success and often cannot be justified in smaller factories.

Correct equipment for an application could be as simple as employing hydraulic rather than manual clamping to actuate jaw closure; using a rotary table to add a fourth and perhaps a fifth CNC axis to a 3-axis machining centre; or choosing a full-length bar magazine rather than a short barfeed to automate a lathe. Whether producing prismatic or rotational components, return on investment (ROI) in such relatively inexpensive workholding and automation can be surprisingly rapid.

All of the equipment mentioned in this article is sourced from overseas manufacturers represented in Britain and Ireland by Salisbury-based 1st MTA, mostly under sole agency agreements. The company operates a consultancy service to identify the optimum production solution, either off-the-shelf or bespoke to address particularly difficult applications and offers the largest variety of both clamping and automation products.

Efficient workholding

In recent years, the trend has been to machine a component in one hit, i.e. without removing it from its fixture and re-clamping it on the same or another machine tool. The result is more good parts in a shorter time and hence higher profitability, but it can only happen if efficient workholding practices are employed.

On lathes, for example, there may be a need for better component accuracy and repeatability throughout a batch to reduce scrap levels. This can be achieved by

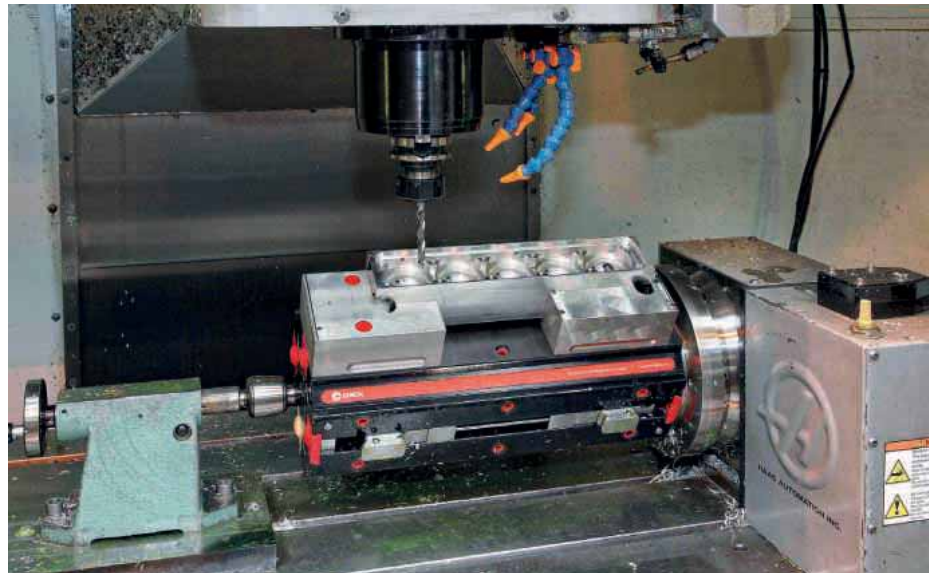

replacing or upgrading a power chuck or installing a collet chuck. It could also mean using special jaws on a standard chuck or utilising one with non-standard features such as a long jaw stroke, or employing face, pull-down or internal clamping.

Perhaps a quick-change chuck may be more suitable, as it reduces setup times, or consideration could be given to a special workholding chuck dedicated to a family of parts. The range of chucks manufactured by the Japanese company Kitagawa covers all of these requirements.

For workholding on vertical- or horizontal-spindle machining centres, quick-change pallet systems are available. Fixtured parts can be secured on zero-point plates such as those made in the Czech Republic by V-Tech. They enable components to be loaded quickly, or pre-loaded outside the machine, either way minimising spindle waiting time and maximising productivity.

Multiple component clamping offers long

machine running times. Parts may be arranged on a rotary 4th axis, allowing several sides of components to be accessed by the cutter. For this type of application, Chick workholding from the US offers highly productive solutions, such as its indexer sub system. For use on dedicated 5-axis machining centres, vices from the German company Best are recommended, as they grip on very little material to expose the maximum surface area for milling and drilling in a single cycle.

If an application calls for magnetic workholding, systems are available in various sizes from another Czech producer Walmag, from small, single magnetic plates to large plates covering a complete machine bed. They are equally suitable for securing parts on grinding machines and may also be used for applications other than on machine tools.

Another solution that lends itself to automated loading and unloading on a machining centre is based on the Kitagawa

Swift Klamp, which relies on the HSK toolholding interface for securing components. Pneumatic detection of correct seating ensures accurate machining and elimination of scrap.

Rotary tables add extra CNC axes

To produce parts cost-effectively, manufacturers must machine them in as few operations as possible. Otherwise, quoting for work is often a waste of time, as it is impossible to compete on price if an operator has to repeatedly reload a part for another operation, not to mention the cost of additional fixtures and the potential for scrap due to loss of component accuracy.

An additional rotary axis from Kitagawa can be deployed horizontally or vertically to provide either rotary motion or a tilt axis for positioning a part. It can be controlled either by the machine tool's CNC system or by a separate controller. The latter is more expedient if a factory has several different makes of CNC in operation on the shop floor, as the table can be moved from one machine to another easily rather than using it on one machine only.

Options include compound tables to turn a 3-axis VMC into a 5-axis machine, elevated clamping tables, small-footprint and high-speed tables and large through-bore models as well as multi-spindle rotary and tilting tables with accessories for automatic loading.

Short barfeeds cannot compete with full-length magazines

A fixed-head turning or turn-mill centre may be automated with a short barfeed but it is worth considering a full-length bar magazine, as is routinely fitted to a sliding-head lathe. 1st MTA's contention is



that repeatedly feeding short bar into a lathe costs the user money, whereas a more productive, full-length alternative constantly saves money. The ROI on full-length barfeed models, such as from the Italian manufacturer, Lemca, is all too often overlooked can be a costly mistake, as substantial savings could be made over a short period by feeding long stock.

Lathes equipped with such magazines, which may be fitted with a rack or bundle loader for holding multiple bars, keep production running for long periods unattended during the day, overnight and at weekends, without having to stop the machine to change the stock. Profitability is raised by keeping the spindle turning for longer, helping to amortise the cost of the long bar magazine very quickly.

1st Machine Tool Accessories Ltd

Tel: 01725 512517

Email: enquiries@1mta.com

www.1mta.com

 **Kawasaki**
Powering your potential

Raising the benchmark

Faster, compact,
energy saving
and affordable...

Kawasaki offers one of the largest robot ranges available today. For assembly, the collaborative duAro. For handling, the 'R' Series (also with IP67 rating). For high-speed spot welding, the BX Series. All robots are now available with attractive and flexible leasing options.



info@kawasakirobotuk.com

kawasakirobot.co.uk

+44 (0)1925 713000

Kawasaki Robotics (UK) Ltd

Canny robot decision brings cost savings

A new Kawasaki robot has been installed to enable Ball Beverage Packaging to improve its efficiency and save money. The machine replaced a near 20-year-old Kawasaki ZD130S robot at the Wakefield plant, bringing greater speed, precision and durability to the customer.

When Ball Packaging needed a new, fully automated waste material conveying and bale handling solution due to increased production capacity, it turned to air technology and waste separation expert Impact Air Systems for a solution. Impact Air Systems, established in 1989, specialises in providing bespoke solutions for the handling and processing of all manner of industrial waste products including metals, allowing manufacturers to maximise recycling opportunities, reduce costs and help look after the environment.

Impact Air System's scrap handling system collects waste material from the beverage can production machinery and conveys it through a pneumatic ductwork circuit to a hydraulic bale press. Once pressed, the bales of waste material are loaded onto transportation and taken to an appointed recycling location.

Ball Packaging is a global leader in beverage packaging with extensive experience using Kawasaki robots and its brief to Impact was to design a new system that would increase production capacity,



replace older equipment, reduce costs and maximise recycling capability.

Kawasaki Robotics recommended its automation systems integrator LAC Conveyors to work with the Impact Air Systems engineering team and together they designed a new system that offered significant savings over the methods that were currently in use at Wakefield. They started by understanding Ball Packaging's

key operational requirements, designing flexibility and reliability into the system.

One aspect of the new design focused on the logistics aspects that take place with the finished aluminium bales after they leave the Wakefield site for recycling. Part of this process involved consideration about the bale stacking process, maximising the road vehicle payloads and also the offloading exercise that needed to take place once the bales reached the recycling centre.

Previously, the bales of scrap material had been stacked by the robot on to wooden pallets, strapped to the pallet by hand, transported from site like most other waste material, then removed from the wooden pallet prior to recycling. Detailed investigation revealed that this process did not provide the best payload economics for transportation and neither did it take any account of how the recycling plant could most efficiently handle the bales on arrival.

As a result of reviewing this part of the process, Impact Air Systems created a new bale stacking pattern that maximised the robot capability enabling bales to be stacked in a pattern that eliminated the use of wooden pallets.

This was achieved by developing a new custom-made transport pallet, mindful of the fact that the stack needed to be within the tolerances described for baling and also the need to try and prevent the shedding of



any debris from the bales during both handling and transit.

By employing a robot to stack the bales in a pre-approved pattern that contained voids allowing them to be handled by a fork truck, they could be moved, stacked and then loaded directly onto a road vehicle in a manner that facilitated swift and easy removal once the recycling centre had been reached, eliminating the use of wooden pallets. Extensive trialling proved the idea and as a result, the customer is now saving time and expense on a scale not previously achievable.

Kawasaki Robotics' Ian Hensman, who sold the original robot to Ball Packaging almost 20 years ago, says: "It was clear from the start of our discussion with Impact Air Systems and LAC that a combination of robot payload, speed and durability was being taken as a given, based on Ball Packaging's previous 20 years of fault-free service from our ZD130S robot. What they needed to be certain of was that the new robot we recommended could cope with new demands brought by rapid growth, lifting anything up to 320 bales on each shift, with each bale weighing around 30 kg.

"For the new system, the scrap

brightwork bales, typically sized 440 x 440 x 280 mm, had to be rotated to the required position for stacking whilst in the transit arc and needed to be placed into the appropriate stacking position with a precision guaranteed to be within 1 mm first time, every time. Further, to cope with increased production levels and also make provision for further future growth, an extremely fast full-cycle time was specified for each individual movement. This also provided an assurance that the new system could absorb peaks in the event of potential spikes occurring in can making production, such as those seen as a result of lockdown."

Kawasaki's engineers recommended the company's CP180L robot for the application. It is approved and certified to carry a payload of up to 180 kg at its maximum reach of 3,255 mm and at this reach the unit operates with a guaranteed positional accuracy of +/- 0.5 mm.

Impact Air Systems' Dave Lansdell oversaw the project: "We identified early on that greater speed and precision were clear requirements as far as the robot element was concerned. Our chosen bale handling integrator, LAC, has a long history of successful problem solving in partnership

with Kawasaki Robotics, and the solution they provided with their CP180L robot for this application was perfect. From our viewpoint, we were impressed with the approach demonstrated by the entire robot and integration team, who provided us with excellent support and delivered first class teaching and training on installation."

Chris Unwin, CEO at LAC Conveyor Systems adds: "Fundamentally, our brief was to reduce labour costs, maximise the recycling opportunities and help minimise transportation costs. In this case, we needed to look beyond the normal points of reference and make our engineering match each clearly defined stage of a waste recycling process. The engineers from Impact Air Systems, Kawasaki Robotics and LAC made a great team and between us we met every objective that was agreed at the start of this interesting project."

Kawasaki Robotics

Tel: 01925 713000

Email: info@kawasakirobotuk.com

www.robotics.kawasaki.com

EROWA®
system solutions



Increase profitability



www.remsystems.co.uk

Tooling systems

With highest accuracy and stability



PreSetting & Quality control

With a high level of mechanical precision



Robotic systems

For small and large workpieces up to 500kg



Job-Management software

For easy control of complex automation cells

EROWA Robot Compact 80 delivers for Norjon Precision Engineering

For over three decades, Norjon Precision Engineering has built and upheld its enviable reputation for superior service and unrivalled quality of specialist, bespoke and tailored precision engineered components for the food, marine, aerospace and power industries to name just a few. Here, a number of EROWA robotic automation systems are helping the company maintain this reputation.

At its impressive facilities in Gosport, Hampshire, the company operates its extensive list of high-quality machine tools around-the-clock to meet the demands for its 'blue chip' customers. With an array of 3- to 5-axis machining centres from Hermle, Makino and Mazak and turning centres from Okuma and Mazak, the shopfloor is also populated by three EROWA Robot Compact 80 automation systems supplied by exclusive UK and Eire agent REM Systems.

Two of the automation systems are fitted to Hermle 5-axis CNC machining centres. Managing director Kevin Fox explains why the company chose to make the investment: "Simply put," he says, "we needed the hours to meet the customer delivery demands for the projects we support. I identified that we could avail ourselves of another 60 hours per week if we run over the



weekend around-the-clock. Just a few weeks after installation the EROWA systems consistently achieved the 60-hour target set."

Floorspace was a further consideration for Norjon as Kevin Fox explains: "We are at capacity in terms of machine tool installations and the Robot Compact 80 with

its small footprint offered a pallet size that suits the components being machined. The EROWA system provides a 32-pallet capacity and the parts we are loading it with typically run for a 2-hour cycle. So, running it all weekend allows us to come in Monday morning with 30 parts finished."

The third system came with a turnkey package from NCMT when the machine tool supplier specified a Makino DA300 5-axis machining centre equipped with the EROWA Robot Compact 80. This system was installed to produce highly detailed aluminium components with typical machining cycle times of around four hours.

Within a storage rack that is just 1 m long the maximum capacity of Robot Compact 80 is 32 pallet locations. However, for this application the rack has been configured with 16 smaller pallets and eight larger ones to accommodate the variety of components being worked on.

This turnkey package is described as 'Premier League' by Kevin Fox: "Our company philosophy is to invest in quality; quality machine tools give you quality workpieces. It really is a no brainer for me."

The EROWA Robot Compact 80 is able to accommodate up to 11 different EROWA pallet sizes for varying workpiece sizes and

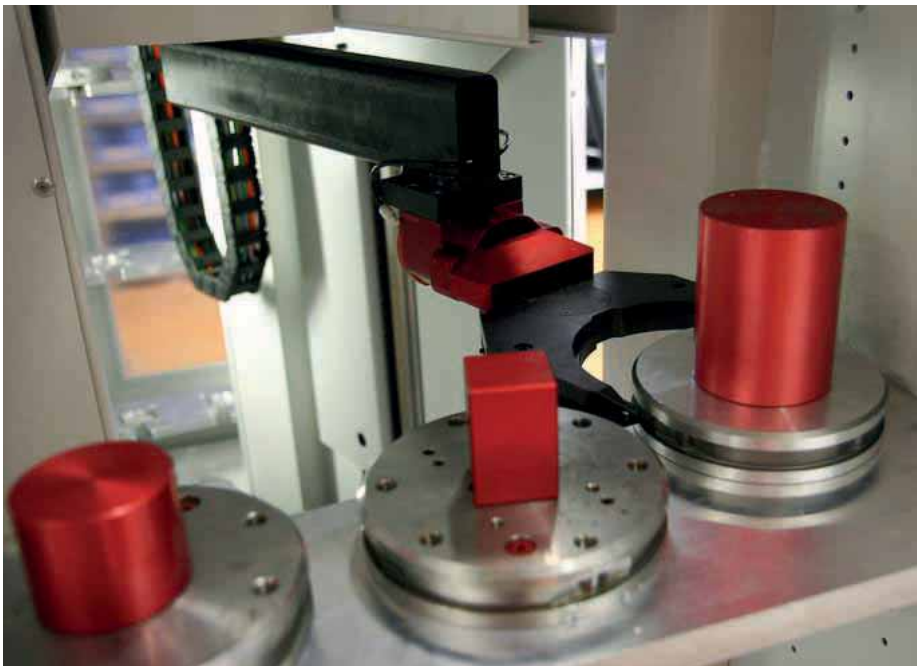

the magazine levels can be set up precisely to meet requirements. Although Norjon Engineering's parts are relatively light the robot is designed to accurately and reliably manipulate pallets weighing up to 80 kg each and can even feed two machine tools. It provides the optimal ratio between a large number of magazine positions and a small amount of floor space. The tall and lean design of the robot means just 2 m² of floorspace is required.

An optional integrated loading station makes it easier for large and heavy workpieces to be positioned in the magazine at an ergonomically correct height. While this is taking place, the robot keeps on working without any interruptions.

The choice of automation provider followed an extensive 12 month investigation of the different robotic systems available and a trip to see EROWA's facility in Switzerland. "I was impressed with the company and my research revealed that EROWA has an exceptional reputation in the market for its robotic systems. The control system for the robot also interfaces very well with the machine's CNC controller," explains Kevin Fox.

"New machine tool investments going forward will also feature automation in one guise or another for any production work carried out. To consistently achieve the finish levels we do for our medical clients and other demanding customers we have to use the very best machine tools and to keep their spindles running we have to use automation systems such as the EROWA Robot Compact 80.

"To achieve the output levels that our robot systems give us we would need two or three more machine tools and we don't have the space or the manpower to do that. It is extremely hard to find additional skilled staff for production work, robotics is the only way I see of meeting this demand. More and more UK manufacturers are taking this step and although the UK has lagged behind Europe with its drive to take advantage of automation, we are waking up to the productivity and efficiency gains that can be achieved."

Of course, these gains can only be accessed if reliable backup is available: "Our working relationship with REM Systems has proven to be very beneficial to us. Their knowledge of the range of solutions on offer

means we are always pointed in the right direction when making an investment and the service and support has been exceptional," Kevin Fox concludes.

REM Systems was established in the early eighties to service Swiss EDM machines. This activity brought the company into contact with the Swiss tooling and automation company Erowa and it has been its distributor in the UK and Ireland since 1987.

At about the same time, it also became the distributor for another Swiss company, TRIAG that produces multi-vise systems. Recently it became the distributor for a third Swiss company, FTool that manufactures EDM tooling systems. REM Systems association with these companies, coupled with many years' experience of machine tools and production engineering, means it is well placed to help customers in their pursuit of lean manufacturing processes.

REM Systems Erowa
Tel: 01452 750581
Email: sales@remsystems.co.uk
www.remsystems.co.uk

Subcontractor upgrades billet production

Contract machining firm microart in Roding, Bavaria, specialises in the production of components in small and large batches to very tight tolerances. The 25 five-axis machining centres and 14 turn-mill centres operate largely unmanned, 24/7, due to extensive use of automation and networking. Founded in 2007, microart has become one of Germany's fastest-growing subcontractors. It currently has 186 employees and an annual turnover of around €14 million.

Due to the high level of precision that needs to be achieved, much of the shop floor is temperature controlled. To ensure that billet material is supplied to the

machine tools efficiently and at a constant temperature, the company has invested in a UNITOWER tower storage system and two automatic KASTOwin A 4.6 bandsaws from German manufacturer, Kasto. All three are adjacent to one another at one end of the factory and the roller door through which new material arrives is carefully managed to ensure it is opened only when necessary and for the shortest possible time.

The cutting range of the saws is 460 mm, large enough for most of the material machined by microart. The stock processed on the saws is stored in the 15.6 m high tower, which has space for 100 cassettes that hold material up to 6.5 m long. Two types of cassette are used with heights of 160 and 300 mm. Up to 2.5 and three tonnes can be loaded into each cassette type respectively. The load carriers are handled by a storage and retrieval machine (SRM) to deliver stock to the operator at ground level. Access times are short and the handling of bulky materials is made easier.

Previously, microart employees had to laboriously store and retrieve long goods manually, but now they only have to push a



button. The SRM automatically finds the relevant storage location thanks to the KASTOlogic warehouse management system. After employees receive order data, they call up the required material via a touch screen and the cassette is delivered to the retrieval station. The stock is then handled manually or with the assistance of an overhead crane onto the input conveyor of one of the saws.

KASTO Ltd
Tel: 01908 571590
Email: sales@uk.kasto.com
www.kasto.com



KUKA posts record robot sales despite challenging year

KUKA Robotics in the UK and Ireland has posted the strongest annual sales figures in the company's history, despite the challenges of the COVID-19 crisis and the consequential recession. The group attributes the success to its proven sales strategies and to four main strategic factors that combined to make 2020 a record year.

With the rise of e-mobility, driven by customer demand for green modes of transportation, the automotive sector has undergone big changes in vehicle design and propulsion. KUKA has been at the forefront of automation for e-mobility production and a big cause for celebration was a large order from commercial electric vehicle manufacturer Arrival, a new company with a unique production model.

Every Arrival vehicle is produced in a relatively small and low cost "microfactory", each of which can produce 10,000 vans or 1,000 buses per year. The company has already announced an order of 10,000 electric vans from logistics company UPS, with the option for a further 10,000; production in the UK is now supported by Arrival's first US microfactory, in York County, South Carolina.

KUKA UK is supplying the robots for Arrival's rising demand across the world. CNBC reported in November 2020 that Arrival was aiming to build three to four of these factories a year, each serving a city and its community, linked in a global framework. The potential for future use of robotics and automation from KUKA is very promising.

KUKA UK appointed a specialist automotive account manager Paul Williams



in late 2019. With a strong track record in automotive robot applications, he has already made big in-roads into the sector.

"The UK automotive sector faces big challenges, but electrification is coming fast and, with winning the Arrival contract, I am confident that KUKA is very well placed to capitalise on this growth market," says Paul Williams.

"KUKA is embedded in the big car plants in Germany but we are not as well established in automotive in the UK, for legacy reasons," says Bernard Bagley, head of robot sales, KUKA UK. "Paul and the Arrival contract are helping to change that."

KUKA has restructured its sales teams under general industry, in order to cover sectors and regions simultaneously and efficiently. Now, every sales manager targets an industry sector as well as a geographic footprint. Along with KUKA's System Partner model of partnering with specialist integrators, the approach is much more customer facing. KUKA brings projects to its System Partners and vice-versa; KUKA sales engineers and System Partners always

"walk the floor" to help advise on optimum automation strategies and act as a trusted advisor.

"This change has generated a lot more interaction with end-customers, which has always been our goal," says Bernard Bagley. "Our System Partners provide this customer focus and our restructured sales team is now doing the same."

Thirdly, KUKA has crystallised its strategy for education and research and development. The company has always believed in the fundamental need for appropriately skilled operators, technicians and engineers, in order to extract the best out of automated machines, assembly lines and research projects. KUKA UK and Ireland have invested heavily in supporting the education and research sectors and have developed dedicated educational robot cells and training material, alongside bespoke research cells focused on emerging technologies.

KUKA Ireland recently won a significant tender to supply the Louth & Meath Education and Training Board (LMETB) with a range of educational and collaborative robots for its new state-of-the-art Advanced Manufacturing Technology and Training Centre of Excellence (AMTCE) in Dundalk, Co. Louth. The training facility at the centre, which is set to be the largest vocational



training facility of its kind in Europe, includes tailored educational industrial 6-axis robots with vision systems, robotic welding cells, robotic milling/machining cells and collaborative robot, cobot, cells.

Brian Cooney, managing director of KUKA Ireland, says "Manufacturing is experiencing a serious skills gap and shortage of resources in advanced manufacturing technologies at vocational level, which is not being addressed by the third level colleges and universities. The investment by the LMETB in this visionary AMTCE training centre is not only addressing this skills gap in Ireland but is also setting the standard by which other European centres may be measured."

The AMTCE provides tailored training courses to upskill and reskill operators and technicians and forms a critical component of the Irish Government's Industry 4.0 Strategy 2020-2025 program and COVID-19 recovery plan.

KUKA Robotics is the only robot manufacturer with a dedicated presence in Ireland with local sales, customer service, application engineering and training. "This recent success is testament to our focus on

providing the best possible products and service to our customers. This is never more important than starting with the operators and technicians who will be responsible for the continued success of our manufacturing sectors," says Brian Cooney.

KUKA UK and Ireland enters 2021 with a very strong team, with experts in sectors, applications, and regions across the board, together with a network of independent Platinum, Gold and Silver level System Partners, who deliver first class solutions and consultancy centred on their core competencies.

Looking to 2021, KUKA believes the robotics and automation sectors are set for significant growth in response to increased demand to offset the heavy reliance on ever scarcer resources, to reshoring, and to escalate efficiencies and competitiveness in manufacturing. New social distancing requirements in factories and workplaces increase the need for automation to create safe working environments within a limited floorspace.

The life-science sector, including medical device, pharmaceutical and biotech, is a notable growth market. Laboratories are

presenting new applications for robots and cobots, especially in labs and clean rooms, that require precise, repetitive processes where a robot can provide the consistency, reliability and traceability that such a highly validated process demands.

Brian Cooney says that, while 2020 has been a difficult year for many manufacturing sectors suffering under the double impact of COVID-19 and the uncertainty around Brexit, it is widely expected that there will be a strong bounce back in the UK and Irish economies in 2021 and beyond. With the benefits of Industry 4.0 and digitisation, together with incredible advances in manufacturing technologies, KUKA expects to take its record 2020 success into 2021 and deliver continued growth, despite the economic challenges.

KUKA Robotics UK Ltd

Tel: 0121 505 9970

Email: sales@kuka-robotics.co.uk

www.kuka.com

FANUC introduces powerful compact general-purpose robot

FANUC has expanded its range of general-purpose industrial robots with the introduction of the highly compact M-10iD/16S.

Building on the capabilities of its predecessors, it combines a slim profile and low footprint with an impressive payload capacity of 16 kg. This represents a significant improvement on previous models and offers great operational versatility for compact spaces in production lines, including top mount applications.

Sales and marketing manager at FANUC UK, Andy Armstrong comments: "Factory floorspace is something that is always at a premium, which is why our R&D process is constantly striving to deliver high performance from a small footprint. The M-10iD/16S represents the best-in-class performance for use in compact robotic cells, especially when complex tooling or handling of heavy workpieces is required."

The M-10iD/16S benefits from a fully integrated hose pack and cable management design, allowing the cables to be led through the robot's hollow arm, wrist

and body. This facilitates easy and reliable routing of sensor or camera cables, air pipes and any other user utilities, eliminating external cables that could otherwise interfere with peripheral equipment.

Andy Armstrong continues: "Incorporating this type of cable management design into the M-10iD/16S helps to simplify the integration process, which combined with an optimised cable lifespan, contributes to easy maintenance and lower lifecycle costs. This forms part of our wider commitment to making it as simple as possible to introduce automation and robots into industrial processes."

Usability is another key element of the M-10iD/16S's design. It can be controlled with the intuitive R-30iB Plus controller and supports various intelligent functions such as the built-in proprietary FANUC iRVision system. It can also be used in conjunction with FANUC's ROBOGUIDE simulation tool, in order to improve the cell design and enhance engineering processes.

Andy Armstrong concludes: "The M-10iD/16S combines performance and



usability, in a compact package that makes it perfect for operating in small spaces within a production line. Its comparatively high payload and reach of 1,103 mm means that the M-10iD/16S is an important addition to our industrial robotics range."

FANUC UK Ltd

Tel: 0121 456 3004

Email: sales@fanuc.co.uk

www. www.fanuc.eu/uk/en

Solution for fixing large and medium-sized components in T-slots and grid plates

Sometimes it is the simple things that provide real benefits for users. AMF has introduced a flexible, modular screw jack for fixing large and medium-sized components in T-slots and grid plates. Individual modules are plugged reliably together up to the required height and a maximum of 1,620 mm are possible. The starter kit, consisting of ten parts, covers a wide range of applications. Basic modules are rounded off by additional accessories, including the matching workshop trolley.

"We cannot explain why nobody has ever invented the modular screw jack until now," states Manuel Nau, sales manager at Andreas Maier GmbH & Co. KG. Indeed, the Fellbach experts for clamping on the machine table have been the first to bring this clever solution to the market.

Various elements can be assembled securely up to the required height in order to fix large and medium-sized components in T-slots and grid plates. The burnished modules made of tempered steel are reliably connected with a threaded ring and allow great flexibility during assembly.

The modules are inserted into T-slots and on grid plates by means of screwed-in base elements. At the top of the vice, a spindle with a trapezoidal thread ensures that it is adapted to the workpiece.

A starter kit for a wide range of applications

The manufacturer covers a wide range of applications with a starter kit consisting of ten parts. This includes a screw jack element with a base element, a small and medium spacer element, three M16, M20, M24 thread adapters, three T-nuts for groove 18, 22, 28 as well as an insertion tool. Additional intermediate elements make heights of up to a maximum of 1,620 mms possible. The permissible supporting force is 60 kN. In addition to this, AMF offers a further support element with a fine thread. The user can adjust this precisely up to a maximum support height of 330 mm under load. Optionally attachable spherical, smooth or selective supports compensate for any unevenness of the workpiece. They are held magnetically, secured with a cylinder pin and can be adjusted with an angle of +/- 3°.



AMF presents a flexible, modular screw jack for fixing large and medium-sized components in T-slots and grid plates. The starter kit consisting of ten parts covers a wide range of applications

The support element can be used in horizontal and vertical clamping.

Practical, easy-to-use and awarded a prize

If T-slots or grids do not fit, base elements can help. They enable variable positioning on the machine table. A workshop trolley with mountings for the modules ensures order and mobile, quick provision at the place of use. The new modular screw jacks from AMF make a solid and well-thought-out impression. They feature impressively high manufacturing quality, flexible application options and improved handling compared to large and heavy elements, which always require a crane. Anyone who sees it for the first time is amazed why it has never existed before.

Andreas Maier Fellbach (AMF), originally founded in 1890, today is a one-stop supplier in clamping technology and is one of the world market leaders. With a global market presence, the company and its employees always provide excellent customer service to its customers. By listening to these needs and through its strong problem-solving ability, professional consultancy, intelligent engineering and high manufacturing quality, AMF repeatedly develops project fabrications and



customised solutions for customers as well as standard solutions that succeed in the market again. With more than 5,000 products and numerous patents, it ranks among the top innovators in the industry. Speed, flexibility and 230 well-qualified employees guarantee success at Andreas Maier GmbH & Co. KG.

Andreas Maier GmbH & Co KG
Tel: 01924 242972
Email: fornsworth@amf.de
www.amf.de

New Widia inserts extend shoulder mill series

Extending the capabilities of its milling portfolio, Industrial Tooling Corporation (ITC) has now expanded the VSM890-12 face and shoulder milling series from Widia. Hailed as one of the very few 8-edged double-sided milling lines with genuine 90-degree milling, the VSM890-12 has been increased with the arrival of its new MM insert geometry.

The high-performance milling line generates superior metal removal rates on a complete range of materials when conducting face, shoulder, Z-axis and contour plunging and 100 percent radial engagement slotting. This operational diversity is a credit to the availability of a coarse, medium or fine pitch insert density that corresponds with a new pocket seat design that enhances stability and rigidity during roughing applications.

To achieve this performance in a wide range of materials, Widia has developed three insert geometries. The ALP geometry has been developed as the first-choice

grade and geometry for the machining of nonferrous materials and this is complemented by the ML inserts for the semi-finish and finish machining of stainless steel. However, to extend the capabilities of the VSM 890-12 to a wider audience, Widia has now introduced the new MM insert designation. This new grade is a general-purpose insert that is perfect for material types from steel and stainless to iron, super-alloys and hard materials. The ability to cater to this expansive range of materials is a credit to the unique insert geometry, substrate and innovative new coating that have all been developed by Widia.

The new VSM890 series is available with a 32 mm diameter Weldon end mill configuration whilst the shell mill tool bodies are available in diameters from 40 mm up to 250 mm with a cartridge face mill providing a 315 mm diameter. The most impressive feature of the WSM890 is its true 90 degrees cutting for wall and step milling. With an integrated wiper facet and super positive

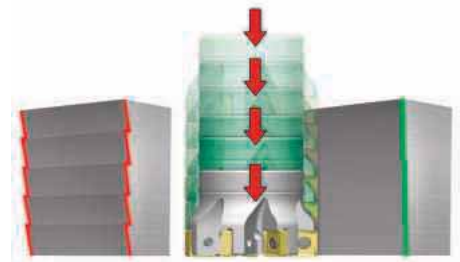

rake design on the inserts, the VSM890 generates exceptional surface finishes and an efficient and smooth cutting action for low-powered machines. Now, ITC can offer this extremely cost-effective milling solution for a wider audience and a greater application range with the new MM inserts.

Industrial Tooling Corporation Ltd
Tel: 01827 304500
Email: sales@itc-ltd.co.uk
www.itc-ltd.co.uk

Sandvik Coromant announces metalcutting collaboration with Autodesk Fusion 360

Sandvik Coromant has announced a new partnership with Autodesk. The collaboration was officially announced in November last year at Autodesk University 2020; the leading online conference for design and manufacturing. The announcement marks the first step of a long-term partnership between the brands, which will deliver significant benefits to the future of Computer Aided Manufacturing (CAM).

The first step of the collaboration will tackle one of the most widespread challenges in CAM, the complex task of specifying cutting tools to determine the most effective way to use them.

Introducing over 2,500 new products per year, Sandvik Coromant is globally renowned for its expertise in machining solutions. The partnership will allow Sandvik Coromant to share this knowledge with even more CAM users in Autodesk Fusion 360.

"Today's manufacturing world is increasingly competitive," explained Jonas Ström, product manager at Sandvik

Coromant. "Materials are lighter, harder and stronger, machines are more advanced, batch sizes are smaller and component design is increasingly complex. All of this leads to an increased need for CAM programming and skilled CAM users.

"As engineers, CAM users love seeking new technologies and testing solutions, but they are often limited by the time constraints associated with CNC machining. By providing them access to tool information, recommendations and knowledge of unique machining methods at the click of a button, we hope to simplify their process."

Typically, CAM users rely on manually transferring data from tooling catalogues and inputting the parameters into CAM software. This process is often laborious and can increase time-to-market expectations.

"Manufacturing and metal cutting are already complex processes and they're often made more difficult by manually managing tooling information resulting in delayed setup times and increased room for machining error," said Srinath



Jonnalagadda, vice president of business strategy for design and manufacturing at Autodesk. "By pairing our CAM software solutions with Sandvik Coromant's deep tooling knowledge and expertise, we're helping customers reduce time and improve efficiency in the preparation phase."

The Autodesk partnership is part of a long-term vision for Sandvik Coromant. The two companies have similar goals; to help customers stay competitive with new technologies and to provide digital design and manufacturing solutions. The first step in this new partnership will remove the time-consuming nature of data selection by providing Autodesk customers with access to the Sandvik Coromant tool data.

Sandvik Coromant
Tel: 0121 368 0305
Email: uk.coromant@sandvik.com
www.sandvik.coromant.com/uk

Face milling cutters with suction effect to keep components chip free

Ceratizit has introduced its PCD MaxiMill SEC12 face milling cutter to the market to target the machining of crankcases, cylinder heads and other automotive-related components made from aluminium and non-ferrous metals, the interiors of which must remain chip-free. Key to the success of the MaxiMill SEC12 is the design of the insert seat and cutting insert topology, supported by the coolant pressure, which create a suction effect, that at high speed clears virtually 100 percent of the chips away from the workpiece.

Anyone working in engine manufacturing will be familiar with this problem. During the conventional face milling of crankcases and cylinder heads, chips fall into the water chambers and get stuck there to such an extent that they cannot be completely removed by the automated washing process. They must be laboriously removed by hand, which involves additional time and costs. And if chips remain, the expensive component might even have to be scrapped.

The new PCD MaxiMill SEC12, Suction Effect Cutter with 12 mm insert size, face milling cutter eliminates this problem, saving time and cost. Thanks to cutting inserts with a ground-in chip removal notch and their clever positioning in the body of the milling cutter, the tool develops a suction effect that clears the chips away from the component. In addition, the working angle from the flat surface is approximately 30 degrees, which means that hardly a single chip can enter the interior of the component. Chip evacuation is further enhanced by coolant flow, which is applied at the optimum pressure behind the chips.

CERATIZIT MaxiMill SEC12 also offers numerous other advantages. One of the most important is its modular design, made entirely of stocked standard components, which enables individual versions to be created for any requirement. The milling cutter consists of a milling adapter in HSK-A63, -A80 or -A100 design, which holds the base body of the face mill. These are available in diameters of 50 Z6, 63 Z8, 80 Z10, 100 Z12, 125 Z14 and 160 Z18 mm, to guarantee ideal, and cost-effective,

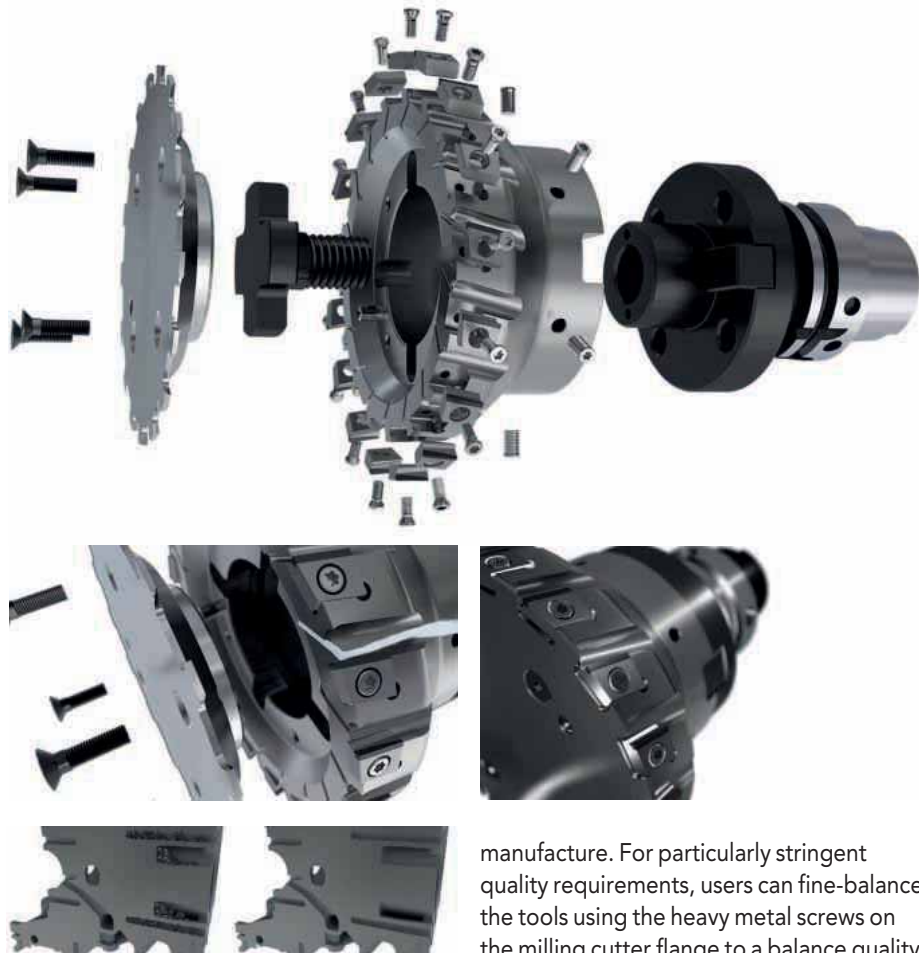

machining results. Further sizes and variants that are customised to individual requirements are available on request.

The PCD inserts are characterised by an extremely long service life with cutting speeds up to 3,500 m/min. Refinements in the geometry of the insert enable feed rates of 0.1 to 0.2 mm per tooth. The number of teeth has been calculated to match the power of standard machining centres available on the market. CERATIZIT is offering two variants for roughing: one for up to 8 mm width of cut and one for maximum 4 mm width of cut that reduces costs due to a lesser amount of PCD being used. This means that customers can independently configure the optimum tool for their application and machine.

Assembling the CERATIZIT MaxiMill SEC12 is a simple Plug & Play solution. Even the inserts can be fitted without the need for adjustment thanks to their precision

manufacture. For particularly stringent quality requirements, users can fine-balance the tools using the heavy metal screws on the milling cutter flange to a balance quality of G2.5. The resulting high radial run-out accuracy preserves the spindle, guarantees a longer tool life and lower vibrations and even enables a surface quality of approx. Rz=20 µm during roughing.

The roughing portfolio of the new Ceratizit MaxiMill SEC12 is now in stock with a finishing portfolio to follow in the near future. This standardisation has further advantages such as permanent availability and an excellent price-performance ratio.

The MaxiMill SEC12 'milling cutter with suction' yields impressive results in practice, for example during the three-sided face milling of a crankcase made from AlSi7MgCu0.5. 40,000 components can be machined per tool lifecycle in an impressive time, to a high quality and virtually chip-free.

CERATIZIT UK & IRELAND Ltd

Tel: 0800 073 2073

Email: tony.pennington@ceratizit.com

www.ceratizit.com

Frozen to the core

Based in France, AMCC is a world leader in the development of advanced technology for freezing small and delicate components for micro machining. Ongoing research and engineering development have seen the company expand its product range with the new GFR series.

Leader Chuck International is the exclusive UK and Eire agent for this impressive and unusual technology, which uses a film of ice to firmly secure parts for grinding, milling and turning operations. Managing director, Mark Jones, says: "Most components that require traditional micro machining operations, in which material is removed from the part, are very fragile and therefore susceptible to damage. AMCC has answered this challenge with an innovative solution that is quick and easy to use."

Designed specifically for clamping via an ice film, delicate parts held with the GFR series are rigidly clamped without any distortion or mechanical stress being transferred over. This makes it ideal for

grinding, milling and turning watch parts, medical implants, jewellery and other finely detailed manufactured goods. The technology is also ideally suited to applications where vacuum or magnetic fixturing could not be applied, for instance, when the components have through holes or the material is nonferrous, such as ceramics or engineering plastics.

In operation, AMCC products are very easy to use. A fine spray of water is laid down on the freezing plate and the component is positioned in a jig or specially designed top plate. The 'freeze' cycle is selected on the compact control unit and within seconds the film of water turns to ice, clamping the component ready for machining. After the machining operation, the 'thaw' cycle is selected and the control unit releases the part.

Mark Jones concludes: "AMCC has a wealth of experience in the field of freeze-clamping small, fragile parts in a



production environment. We can tap into this knowledge and provide UK engineering businesses facing the demands of micro machining with a proven, cost-effective solution."

Leader Chuck Systems Ltd
Tel: 01827 700000
Email: mjones@leaderchuck.com
www.leaderchuck.com

Kennametal introduces flat bottom geometry for KenTIP FS

New replaceable drill tip saves tooling costs and eliminates process steps

Kennametal has expanded its replaceable drill offering for KenTIP FS modular drill series with the new FEG insert for flat bottom hole applications. Applicable in steel, cast iron and stainless steels, the FEG insert eliminates end milling operations and completes a task in a single operation, saving time and tooling costs.

Drilling flat-bottom holes is a challenge, so is drilling on inclined or curved surfaces, drilling into cross holes, drilling stacked plates and drilling into cross holes, stacked plates and castings and other rough surfaces. Leveraging the success of its KenTIP FS modular drill, Kennametal has developed a unique insert geometry (FEG) that streamlines many of these types of applications and simplifies the drilling of counterbores and pilot holes as well.

"The FEG insert is so versatile, you can use it for nearly all your drilling applications," says Georg Roth, Kennametal's global product manager of holemaking for modular drilling tools.

Conceptually, the FEG geometry design is

simple. It features a 180° cutting edge and a conical centre point, which acts as a pilot to provide exceptional hole position and straightness. Corner chamfers serve to protect the cutting edges and reduce exit burrs. Four margin lands provide stability when breaking into interrupted cuts and cross-holes. And Kennametal's KCP15A grade uses a nano structured AlTiN coating and fine grain carbide substrate, providing both toughness and wear resistance when drilling steel, stainless steel and cast iron.

The diameter range covers 6.0 – 26.0 mm, 0.236 - 1.024 in and drilling depth of up to 12 x D is possible depending on the KenTIP FS modular drill body.

With over 80 years as an industrial technology leader, Kennametal Inc. delivers productivity to customers through materials science, tooling and wear-resistant solutions. Customers across aerospace, earthworks, energy, general engineering



and transportation turn to the company to help them manufacture with precision and efficiency. Every day approximately 10,000 employees are helping customers in more than 60 countries stay competitive.

Kennametal UK Ltd
Tel: 01384 408060
Email: anna.mason@kennametal.com
www.kennametal.com

Making your mark with browser-based FOBA Go

As each new generation of production system is launched, we rightly expect greater levels of flexibility, functionality and ease-of-use. This is true of virtually all technologies including lasers, where the power and performance characteristics of today's lasers have made them the process of choice for many applications. The latest innovation from laser marking specialist FOBA is a new and first of its kind browser-based interface, which means users can use any browser on any device to control their FOBA Laser System. In this article, TLM Laser's Andy Toms, UK and Ireland distributor for FOBA Laser, explains the benefits of this revolutionary approach to controlling and operating your laser system:

Using FOBA Go means that users are not affected by revisions or upgrades to traditional operating systems. Typically, as these operating systems become older they are either incapable of being upgraded or ongoing support is withdrawn rendering them useless.

FOBA Go, Linux-based remote laser software, on the other hand, can be operated using any PC, touch screen, tablet or other mobile device such as your phone. All of the major browsers such as Google, Firefox, Safari, TCT, etc and all industrial communication protocols are compatible. Other useful features of this new innovation include the ability to control multiple lasers using several different tabs within your browser.

FOBA Go is the perfect laser interface for simple marking jobs and, with remote connectivity, laser Marking on the Fly



(MOTF). This game changing software is an ideal partner to the recently launched FOBA TITUS, the smallest laser head in the world, as well as FOBA's new entry level fibre system, the compact Y.0200-S.

The revolutionary TITUS laser head is up to 90 percent smaller in size and weight than other laser heads. This small size makes it incredibly easy to integrate and fit into existing manufacturing lines, opening up new opportunities for laser marking and cutting installation time and costs. Other advantages include straight ahead or 90° beam exit options, clamp 'n' go laser head brackets and an integrated focus finder for speedy focus adjustment. There's also a pilot laser for job simulation and the option of an extra-long 10 m umbilical for even greater flexibility.

Another ideal candidate for use with FOBA Go is the Y.0200.S Fiber Laser, available with 20W output power, which uses several enhanced features to provide



increased productivity and flexibility. This system has been designed to meet the demanding production schedules, often found within in the electronics, automotive and metal and plastics processing sectors. There's a choice of a 6 mm marking head for high-speed production or a 10 mm head for fine detail parts marking. Using the 6 mm head, and depending upon application, marking speeds of 1,300 characters per second can be achieved. The 10 mm marking head provides a flexible option for marking speeds of up to 1,000 characters a second.

Additional information on the revolutionary browser based FOBA Go interface, the super small and easy to integrate TITUS laser head and the entry level, high productivity FOBA Y.0200S Fiber Laser are available from Bromsgrove-based TLM Laser.

TLM Laser
Tel: 01527 959 099
Email: sales@tlm-laser.com
www.tlm-laser.com

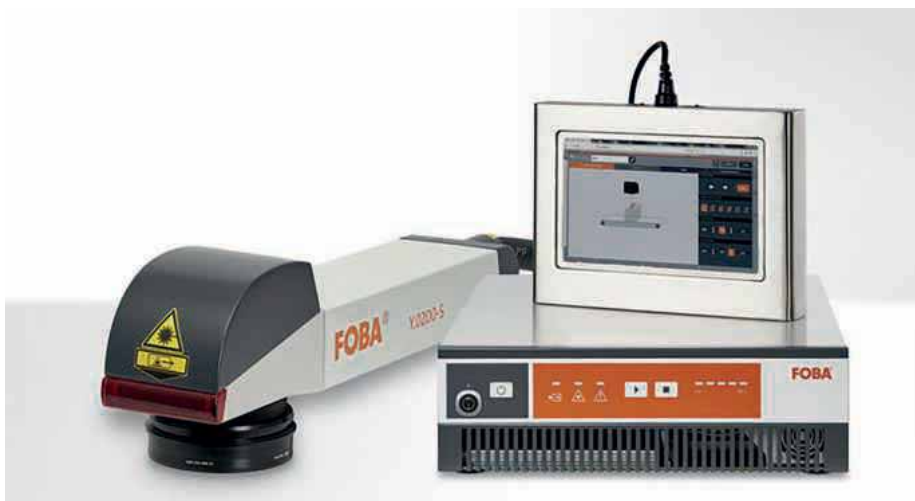

Quality marking at an affordable price

The versatility and low cost of electrochemical marking technology make it the ideal technology for applying high quality marks for traceability or identification of a wide range of different metal components whatever their size, shape, thickness or hardness.

Metaetch systems can deliver high contrast permanent marks which are virtually stress free. Marking is fast with most marks being produced in 1-4 seconds. Mark on any conductive metal surface including stainless steel, carbon steels, mild steel, titanium, Inconel etc and below surface etched marks on metals such as aluminium and brass. Electrochemical can also mark thin wall section that can be distorted by the heat of laser marking and the impact of dot peen.

Stencil software enables you to produce stencils that can mark the new UKCA symbol, datamatrix, incremental serial numbering, date/timestamp, logos, symbols and graphics, text on an arc etc. All the data you wish to mark can normally be done in

one operation. The marking kits are portable to be used wherever they are needed.

Design your own nameplate layouts and panels for enclosures for example, including logos, symbols and boxes which can be saved as a template. Retrieve the file when needed and add the variable data before printing the stencil and marking. The generous sized 105 mm wide thermal stencil paper allows production of large nameplates if needed. If sequential numbering, the thermal stencil printer has a partial cut facility allowing a batch of numbers to be printed in a strip, separated by a small tab, so they stay in order but are easy to separate for marking.

A wide range of accessories include a reservoir assembly for our range of carbon marking heads. The reservoir holds the electrolyte keeping the marking clean and easy to apply the marks. With in-house 3D CAD and manufacturing capability, as well as a 3D printer, Metaetch systems can make low-cost jigs and fixtures to make the



marking cycle even faster. Our electrochemical marking systems are aerospace and nuclear industry compliant. The high purity aerospace and nuclear grade electrolytes are independently lab tested to ensure they comply with the most stringent standards.

Electrochemical marking is used widely across industry where our electrolyte has been cytotoxicity tested and deemed safe for surgical items and implants.

The Metaetch branded range of equipment is wholly manufactured in the UK.

Universal Marking Systems

Tel: 01420 565800

Email: info@ums.co.uk

www.ums.co.uk



XXL-BOX LASER MARKING WORKSTATION



The most competitive solution for marking large workpieces.

SIC MARKING LIMITED

Unit B1, Harris Road,
Wedgnock Industrial Estate
CV34 5JU, Warwick - England
0044 (0) 1926 830372
salesuk@sic-marking.com



 sic-marking.co.uk

Record working dimensions for the new XXL-Box

"After the huge success of the L-BOX and XL-BOX, our compact marking stations, we have been asked on numerous occasions to offer a larger workspace in order to be able to mark large parts." These are the words of Eric Brechenmacher, sales & marketing director at SIC Marking, leader in industrial traceability, to justify the launch of the new XXL-BOX Laser Marking Station.

Available in three basic sizes at a very competitive price, the XXL-BOX perfectly complements the company's laser workstation wide range of products, which makes it possible to meet all customer requirements in terms of cabinet size.

As its name indicates, the new XXL-BOX station offers record working dimensions, up to 520 mm high, as well as great modularity thanks to its three standard models, 800, 1,200 and 1,600 mm wide and its numerous accessories. The strength of this new product also lies in its ability to adapt perfectly to different customer requirements, illustrating Sic Marking's extensive know-how in the realisation of tailor-made solutions:

"The XXL-BOX is ideally suited for the classic use of its large working volume, but also enables the project manager at SIC Marking to offer tailor-made solutions for more complex large-volume marking applications. Project manager Nicolas Ecoiffier highlights the flexibility of this new product through a large number of accessories: "Automatic three-dimensional axis, automatic loading system, loading drawer or turntable are just a few examples of the applications proposed by our technical teams to meet our customers' needs."

Requested by a large number of customers, the new XXL-Box Laser Marking Station has met a great success with ETIs and large companies manufacturing large parts or sub-assemblies such as shafts, valve or pump bodies, crankcase, exhaust



components but also bodywork sub-assemblies. It is not surprising to find it in the sectors in which the company is already active: automotive, aeronautics, industrial vehicles, hydraulics and oil and gas.

As a result, the international French group had the opportunity to prove all the qualities of its new product by taking up the challenge offered by a major German automotive supplier. The company wanted to mark a Datamatrix code on gearbox prototypes. The solution provided was an XXL-BOX laser marking station, with a 5-axis laser that made it possible to achieve a marking window of 900 x 500 x 500 mm. The project was the result of a technical and commercial cooperation between the headquarters and SIC Marking GMBH, the group's German subsidiary and highlighted the great adaptability of this new product to customised requests and the group's ability to monitor projects at an international level.

SIC Marking is an expert in marking and traceability for the automotive, aerospace, mechanical and energy sectors. The company has more than 300 employees worldwide with a turnover of €55 m. It operates in more than 50 countries and has nine subsidiaries. Its offering consists of standard and customised solutions in laser, dot-peen and scribing technologies as well as various associated services including customer support, spare parts, training, retrofit, maintenance contracts. SIC Marking has a customer-oriented culture and promotes operational excellence to



enhance the customer experience. The business is based on permanent identification and complete traceability of industrial products and components. Since 1986, SIC Marking designs, manufactures and distributes dot peen, scribing and laser marking machines.

With 20 years of experience, the group has become a leader in the market. SIC Marking is able to design applications for a wide range of materials, such as steel, alloys, stainless steel, titanium, aluminum, and plastics.

Excellence, expertise and innovation are the values inscribed in SIC Marking's DNA. Driven by its strong principles, the company and its employees have built trusting relationships with various customers. Thanks to this commitment, it has become a performing group, in constant development worldwide.

SIC Marking UK
Tel: 01926 830372
Email: salesuk@sic-marking.com
www.sic-marking.co.uk

Graphtec GB 'makes the cut' with new laser engraving machines

Following its appointment as the exclusive UK and Ireland distributor for Portugal-based WID Innovations, Graphtec GB has now added the latest WID C Series of dual laser engraving/cutting systems to its increasingly diverse range of material finishing solutions. Available in a choice of four different-sized models, the 500, 700, 900 and 1000, the machines are robustly constructed and of a compact design to facilitate installation in production areas where space may be at a premium.

The C Series of machines have respective processing areas of 700 x 500, 1,000 x 700, 1,300 x 900 and 1,300 x 900 mm, with variable cutting speeds of up to 90,000 mm/min. They incorporate CO₂ tube and on selective models RF (Radio Frequency) lasers, sourced through partnerships forged with leading specialist laser manufacturers, with power ratings ranging from 60 W up to 120 W. The systems are supplied with dedicated multi-tool software, are compatible with AI, DST, PLT, BMP and DXF graphic file formats and provide USB and Network connectivity.

Key design features include automatic

temperature and air control systems and smoke/dust extraction and waste retrieval units. An autofocus-empowered CCD camera ensures precise material/object recognition, adjustment and alignment to accommodate the most complex applications likely to be encountered.

Developed to complement the varying skill levels of both entry-level and seasoned professional operatives and for use in applications not suited to conventional CNC routing/cutting/engraving systems, the WID C Series of machines will laser cut and/or engrave a wide range of disparate materials. These include, for example, acrylic and various plastics, hard surfaces such as slate, solid woods and non-ferrous metals like aluminium.

In a separate development and as part of its partnership with leading global software developer SA International, Graphtec GB is now supplying the latest Version 6 EnRoute routing, engraving, milling and cutting software. Available in a choice of four different programs, it incorporates 40 new design and production tools to accommodate the 2D and 3D requirements



of CNC routing/engraving and laser, plasma and waterjet cutting machines.

Graphtec GB
Tel: 01978 666700
Email: sales@graphtecgb.co.uk
www.graphtecgb.co.uk

Part Marking Solutions

Delivering Speed, Quality, Precision & Reliability

- ▄ Electrochemical Marking
- ▄ Dot Peen Marking
- ▄ Laser Marking



Manufacturing and supplying marking systems for over 55 years

Universal Marking Systems Ltd

www.ums.co.uk

T: 01420 565800

E: info@ums.co.uk



+44(0)1527 959 099



BROWSER BASED LASER MARKING WITH FOBA Go



- Control your laser from any desktop or mobile device
- Compatible with all major Browsers and industrial communication protocols
- Control multiple lasers from several browser tabs
- Perfect solution for simple marking jobs



Agents & Distributors For:



www.tlm-laser.com | sales@tlm-laser.com

Measurement efficiency increase for Williams Aerospace Engineering

Williams Aerospace Engineering has invested in a Baty Venture XT CNC Vision System to measure critical precision machined components manufactured at its facility in Northam, Southampton. Specialising in 5-axis CNC turn/mill centres, 4-axis milling, internal and external gear and spline cutting, internal and external grinding, match grinding and honing with sizes from 0.062" - 6" diameter, the business works to tolerances of .002 mm, 0.00007, with one microinch surface finish.

Components machined by Williams Aerospace Engineering are used in some of the most extreme environments, including aerospace, defence, nuclear, medical, Formula 1/performance sports car and commercial markets. In order to meet the demands of specific customers, the company manufactures anything from one off components to large batches.

One of the biggest challenges facing Williams Aerospace Engineering was the sheer amount of time it took to measure components and collate all the data for its customers. For example, for a customer with particularly high measurement requirements, it would take the quality department 1-2 days to measure the positions of two holes on a batch of 100 cover plates, in addition to having to input data to an Excel spreadsheet to customer requirements.

Since the investment in the Baty Venture XT CNC Vision System, this measurement process can now be completed in just two hours, which is a massive 96 percent increase in measurement efficiency. The inspection team at Williams Aerospace Engineering is able to load the fixture onto the machine, insert a part, recall the programme and teach the datum position, completing the batch of the same 100 parts within this much shorter timeframe.

David Fripp, managing director at Williams Aerospace Engineering, says: "The Baty Venture XT helps to ensure our product quality by giving us a more consistent and repeatable measurement method. Once a program is written, the Venture is far more accurate than our old manual CMM, which is reliant on the points taken by the operator moving the probe by hand, rather than the CNC control on the Baty system. It is very easy to use and the camera resolution is far more accurate than a standard projector using surface illumination."

Williams Aerospace Engineering uses the vision system for measuring lengths, radii, rads and angles. The measurements are either taken directly from the part loaded on the machine, or if it is an internal feature, it is reproduced using a rubber compound. The mould is then sectioned and measured on the projector as with an external profile.

David Fripp continues: "The Venture gives us the flexibility to measure countersink diameters whilst measuring hole positions on the same part. Due to the camera's focal length, it is also possible to focus on counterbores or countersinks that are located within a bore and take measurements, rather than take a mould and use a standard projector. We're very much looking forward to seeing how much more we can achieve with this piece of equipment in the future."

The Baty Venture XT is used most days either to perform first off,

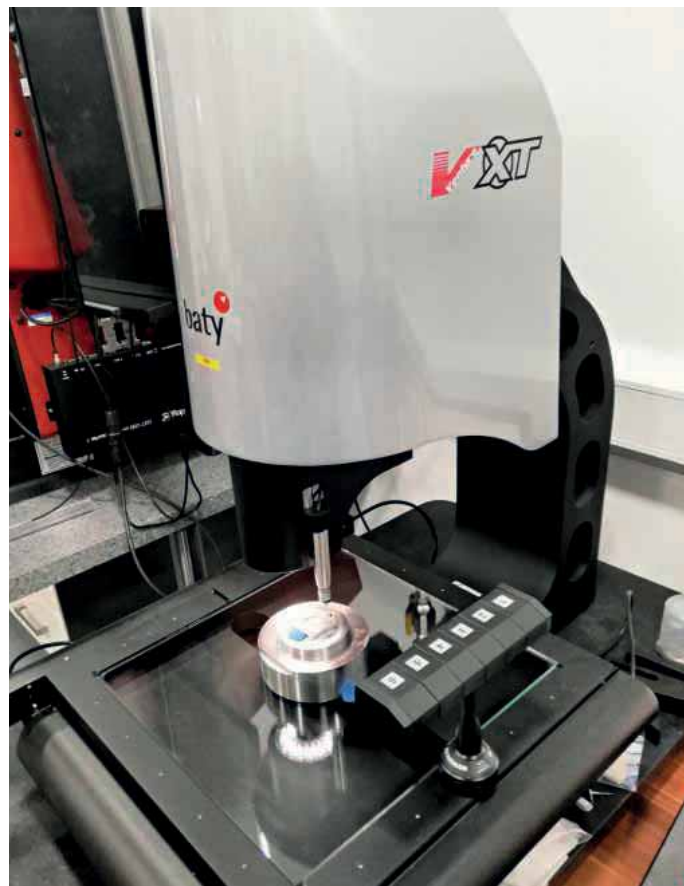

in process, or final inspections on parts which are being manufactured at the facility. Two members of the inspection team at Williams Aerospace Engineering currently use the Baty Venture, but as programs and fixtures become available to use in the future, other personnel will be able to recall programs and perform their own in-process inspections. This will then allow the inspectors to concentrate on other areas.

Incorporated as City Tool & Gauge in 1935, which became N. Williams & Co (Southampton) Ltd in the early 1960's, and finally renamed as Williams & Co (Southampton) Ltd, Williams has been at the cutting edge of engineering ever since. The business also offers full inspection capabilities to check surface profile, such as roundness, cylindricity, and concentricity, which are fully calibrated to ACAS Standards.

As a leading supplier of quality metrology instruments to organisations throughout the world, Bowers Group has developed into a respected global leader in the field of measurement. Its first-class reputation has been built on the continuing Group ethos of striving for excellence.

Bowers Group
Tel: 01276 469866
Email: sales@bowersgroup.co.uk
www.bowersgroup.co.uk

Altus offers transparency on 3D optical measurement

The increasing complexity of electronic devices, coupled with the growing demand for higher quality control and process improvement mechanisms, is escalating the importance to identify any potential problems quickly during the manufacturing process. Key to this is the use of sophisticated inspection equipment. Koh Young, a global leader in both AOI and SPI technology, has further enhanced its offering with an added development to Neptune T, the industry's first 3D light measurement instrument for transparent materials. Altus, a leading distributor of capital equipment in the UK and Ireland, is ready to present the innovative system to its customers.

Neptune T from Koh Young is a pioneering system that cleverly uses non-destructive 3D inspection technology to examine the thickness of transparent and semi-transparent materials like coatings, underfill and epoxy used on a Printed Circuit Board (PCB). This ensures the conformal coating used to protect the delicate circuitry is applied correctly and will ensure the device operates as it should.

Expanding on the capabilities of Neptune T, Koh Young has advanced the system with the next phase in its development. This is to inspect batch and inline conformal coating systems using data aggregation and data-driven process.

Joe Booth, Altus' director of business development and marketing, says: "The inspection of transparent materials like conformal coating is extremely important to ensure quality control and ultimately guarantees that the device will function correctly in its given climate. Think of the impact 3D measurement had on AOI and SPI in comparison to 2D systems. Well the Neptune brings 3D inspection to coating. Given how much critical electronics is manufactured in the UK, this product promises to be a game changer for process improvement and monitoring in our markets."

"The developments that have been made will help to bring data-based decision making that has been so successful in AOI and SPI into a traditionally subjective process, to the conformal coating process."

"Inspection systems used in electronics



manufacture could traditionally detect the presence of coating, however they were unable to inspect the thickness. This missing element meant some PCBs went through the production line without the correct protective layer.

"This advancement will be a huge quality improvement across material dispensing and help in the manufacture of critical electronics. We are looking forward to presenting the updated Neptune T to our customers."

Altus Group Ltd
Tel: 01386 791074
Email: sales@altusgroup.co.uk
www.altusgroup.com

New flexible and precise power tool for easy 3D inspections

The T-SCAN hawk is the ZEISS answer to a broad range of inspection tasks around the shop floor that have to be done on-site. The portable, stand-alone, hand-held laser scanning system comes with the pre-installed GOM Inspect Suite inspection software and delivers precise 3D data and high-quality results. The flexible 3D scanner gathers measurement data in production environments, labs or at the workbench which are then used for quality controls of parts and tools, reverse engineering, or other purposes.

The portable 3D laser scanner boasts important technical features such as



large-object photogrammetry, multiple laser sources and three scanning modes. Thanks to its integrated photogrammetry, it can digitise large and heavy objects very accurately. It comes with two laser sources, red and blue, which can scan various surface structures and materials and even dark and shiny objects, deep pockets and small details. Users can also change the scanning mode while scanning. The ZEISS T-SCAN hawk collects 3D data even on moving or vibrating objects.

The portable ZEISS T-SCAN Hawk is a useful tool for 3D inspections of wear and damage and for matching actual data with CAD and thus makes life easier for users in maintenance, repair and overhaul. Areas such as 3D printing, rapid prototyping and reverse engineering are also perfect application fields for the flexible system. The pre-installed GOM Inspect Suite software guides the user through the entire workflow of scanning, probing and inspecting, making the process fast and easy.

The 3D metrology specialist GOM has

become a standard in many industries with its all-in-one GOM Inspect software. GOM's new software platform GOM Inspect Suite embraces and facilitates the complete workflow from scanning to reporting for maximum ease of use. GOM Inspect Suite offers a host of inspection features and is available for free after registration. The full version of GOM Inspect Suite provides the full extent of data analysis and template capabilities. Users can download a free 30-day trial version to test out the software and its professional features.

HandsOnMetrology.com is the new go-to for everything you want to know about 3D scanning. The digital platform is operated by GOM, a ZEISS company, setting standards in optical 3D metrology.

GOM UK Ltd
Tel: 02476 639920
Email: info-uk@gom.com
www.gom.com

Multi-sensor metrology pioneer toasts 75th anniversary year

A multi-sensor metrology specialist is celebrating 75 years at the forefront of manufacturing innovation. Optical Gaging Products, represented in the UK by Derbyshire-based OGP UK, has spent the past three-quarters of a century forging a reputation as a leader in the production of state-of-the-art measurement systems for industrial quality control.

OGP systems utilise a combination of best-in-class optical, laser and tactile sensors, eliminating the need for multiple specialised measuring systems and collecting highly accurate data even on the most complex components and features, with speed and reliability.

Edward T Polidor, Chairman and CEO of OGP, a division of Quality Vision International, says: "In my time with the company, I have witnessed a dramatic change in how optical instruments perform measurement.

"When OGP was founded 75 years ago, users typically relied on microscopes and optical comparators, depending entirely on their own judgement to ascertain the measurement. Today, the modern automatic video measuring system is completely computer controlled, using video cameras that depend little on the operator's visual skills to produce accurate measurements.

"How these systems became more accurate, automated, faster and ever more capable is OGP's contribution to this remarkable transformation."

Working to sub-micron precision, OGP systems stand out in an era of miniaturisation where new material developments and ever-tighter tolerances have made components increasingly challenging to manufacture.

By making more accurate data available to production engineers in real time, OGP technology empowers them to identify and rectify quality control flaws instantly, leading to less scrap, fewer production bottlenecks and higher productivity.

OGP UK managing director Chris Fulton says: "OGP systems have played a vital role in ensuring the quality of components used in a wide variety of industrial success stories, from smartphones to electric cars and even the space programme.

"Consumer goods produced in the UK and exported around the world contain



parts measured on OGP systems and we're very proud to be setting the pace in the metrology industry.

"Employees of OGP innovate and execute every day, producing practical solutions for our customers' most challenging measurement tasks. The company's 75th anniversary is the perfect time to celebrate that."

OGP can trace its roots back to 1945 in Buffalo, New York, when a new company was formed to support the fledgling optical comparator industry.

In those very early days, as part of a working relationship with Eastman Kodak, it played its part in the introduction of the telecentric relay lens principle, which is still regarded as the optical system of choice for high-precision machines.

Across the decades since, OGP's market-leading technologies have acted as a growth engine for manufacturers everywhere.

It introduced the Vidicom Qualifier, the first truly revolutionary computer-controlled automatic video measuring system, in 1980, then pioneered multi-sensor measurement by adding lasers and touch probes to video systems in 1986 with the IQ-2000.

Today, OGP's flagship Vantage range features a combination of self-calibrating TeleStar optics alongside automatically deployed lasers and probes, so that the machines seamlessly deliver hundreds of part measurements in 3D graphical displays,

without the need for operator intervention.

More information about the full range of OGP technologies can be found online at www.ogpuk.com

The Carfulan Group is a family-owned business, founded in 1989, made up of a team of engineering experts and based at its Innovation Centre in Foston, near Derby.

It specialises in providing the most advanced manufacturing technology solutions available on the market, helping to bring ideas into reality and streamlining company processes, across four divisions: OGP UK, SYS Systems, ZOLLER UK and VICIVISION UK. Its work covers supplying and servicing for multi-sensor inspection equipment, 3D printing and tool pre-setting and measurement, as well as turned-part measurement solutions.

Clients include world-leading companies in the aerospace, automotive, oil and gas, medical, education and 3D design sectors. Over the past decade, the Carfulan Group has enjoyed huge growth. It now employs more than 50 people with plans in place for further expansion.

OGP UK Ltd
Tel: 01283 585933
Email: info@ogpuk.com
www.ogpuk.com

Optical Micro CMM installed at AMRC

This successful partnership between Bruker Alicona and the AMRC has continued with the installation of an Optical Micro CMM at the world class centre for Advanced manufacturing in the UK. With the new μ CMM the AMRC now has four focus variation optical metrology systems and indicates its commitment to optical metrology.

When asked about the new system, the AMRC metrology manager, Richard James says: "We are very excited to have this state-of-the-art optical metrology system at the University of Sheffield Advanced Manufacturing Research Centre (AMRC). The capabilities of the system greatly enhance our metrology capability, the ability to measure vertical walls inside holes is going to be a game changer in our 'One Way Assembly' grand challenge research programme. We have had a long relationship with the Alicona products which have helped the AMRC in many research projects into advanced manufacturing techniques which are now in production environments. We look forward to continuing this collaboration with Bruker Alicona in the future."

The μ CMM, is the first purely optical CMM. It is used to measure extremely tight tolerances in high accuracy. Users combine the advantages of tactile coordinate measuring technology and optical surface measuring technology to measure the dimension, position, shape and roughness of components with only one sensor. The optical CMM offers high geometric accuracy of several optical 3D measurements in relation to each other, enabling the measurement of small surface details on large components and precisely determining the position of these individual measurements in relation to each other. The spectrum of measurable surfaces includes all common industrial materials and composites such as plastics, PCD, CFRP, ceramics, chrome, silicon. Simple operation is implemented by single-button solutions, automation and ergonomic control elements such as a specially designed controller.

Bruker Alicona is a global provider of optical, industrial measurement technology for quality assurance of complex components of different shapes, sizes and materials. Its non-contact measuring



systems are used in all areas of precision manufacturing. Its core competence is the measurement of dimension, position, shape and roughness in the fields of production measurement technology and automation, prototype development

Bruker Alicona
Email: sales.alicona@bruker.com
www.alicona.com

PIPS technology makes custom modification straightforward

Positek Ltd, a leading UK displacement transducer manufacturer, recently completed the design and supply of a custom modified version of its PIPS™ equipped P103 series short stroke linear position sensor for a wastegate valve position feedback task on an advanced automotive turbocharger. As part of a motorised control system that regulates and optimises peak engine performance, the compact pushrod style P103 is mounted near the direct flow hot engine exhaust gases where its specially designed thermal shield allows use at elevated temperatures of up to 160°C at the inductive sensing element whilst the conditioning electronics remain at around 125°C.

Positek's patented PIPS inductive technology is based upon a simple, single coil design which facilitates straightforward customisation, often with the benefit of reduced lead times which in some cases can be as short as a few days. When compared with other available LVDT and magnetostrictive sensor types, PIPS based displacement sensors overcome problems

such as bulky coils, poor length-to-stroke ratio or the need for special magnetic materials. For simplified control they do not require separate signal conditioning. As there is no contact between the moving electrical components, the technology yields extremely long life when compared to potentiometer based equivalents. Even as standard components the robust technology has excellent resilience to shock and vibration with respective specification values of 10g, IEC 68-2-6 and 40g, IEC 68-2-29. These factors combine with typical IP67 protection ratings and full compliance to EN61000 for both susceptibility and radiated EMC.

For the wastegate valve application, the stainless steel housed P103 series sensor includes a special threaded mounting that aided compact installation for the customer as well as the standard options of spring-loaded pushrod and cable gland. The electrical characteristics combined a 4.5V DC calibrated output from a +5V DC supply. A wide range of alternative electrical options are available across the standard



range along with mechanical options that include flange or body clamp mountings and free or captive push-rods.

The 35 mm diameter P103 series short stroke position sensor has any measurement range up to 50 mm, a version for longer measurements up to 100 mm is also available. With independent linearity to < +/-0.25 percent, < 0.1 percent option available, with essentially infinite resolution and a low temperature coefficient, the sensor provides highly accurate and repeatable position measurement over a wide temperature range.

Positek Ltd
Tel: 01327 351004
Email: graham@variohm.com
www.positek.com

RADAN delivers higher profit margins in subcontractor's Smart Factory vision

Powerful automatic nesting in RADAN CAD/CAM software achieves a sheet metal subcontractor's target for its raw material utilisation as part of its Smart Factory vision.

Alpha Manufacturing provides a full range of sheet metal services across a number of industry sectors, including automotive, agricultural, healthcare, retail and electronics. The company was established in 1989 specifically to manufacture products for its sister company, Bri-Stor Systems, which had been set up six years previously. Bri-Stor are specialists in light commercial vehicle conversions, supplying internal racking, roof equipment, on-board power and accessories.

Bri-Stor and Alpha Manufacturing share a 35-acre site at Hixon, in Staffordshire. Bri-Stor's solutions comprise consultancy and design through to in-house manufacture, installation and livery application. Customers range from those with just a few vehicles, to hundreds and include many well-known UK fleets.

Modular products for standard conversions include options designed for particular sectors, while bespoke solutions create kits which are fully customised around the specific needs of the customer's fleet. For example, the Vantage range is an innovative storage system that maximises the usable space within the van. Unlike most internal racking systems, this features an asymmetric design which allows up to three times more tools or materials to be stored.

Initially Bri-Stor outsourced its sheet metal fabrication requirements, before the decision was taken to build up its own manufacturing arm with Alpha Manufacturing. Alpha's marketing manager Chris Kidney, says: "Originally we were dedicated to producing the van kit-out components for Bri-Stor, but fast-forward to today and we now have a large portfolio of



subcontract work, which actually outweighs our Bri-stor production."

All components for both sides of Alpha's business go through the dedicated sheet metal CAD/CAM software, RADAN, from Hexagon Manufacturing Intelligence. He says it's extremely important that the parts are high precision, often needing to be within +/- 0.2.

The process begins with laser cutting and punching on TRUMPF, Bystronic and Pullmax CNC machines programmed with RADAN toolpaths and nests, before moving through the factory for folding, fabrication, welding, powder coating and assembly.

Its team of three full-time programmers makes full use of RADAN's powerful nesting functionality, analysing the true shape, material, and thicknesses of all components in a batch, separating and sorting automatically, to produce manufacturable, high utilisation nests both from full sheets and offcuts.

When the nests have been finalised and are ready for cutting, two of Alpha's machines, a Trumpf TruPunch 6,000 laser/punch combination machine and a Trumpf S12 punch press, can both feed off a Stopa automated storage system which leads to even greater efficiency and time savings. The entire Stopa now runs 62 m down the centre of the factory and contains 230 pallets capable of storing a total of around 600 tonnes of sheet metal. It

manages the process of automating stock storage and movement between machines, with all raw sheet metal stored in the towers and able to be called on at the touch of a button.

Chris Kidney concludes: "The fact that we can process the parts extremely quickly, from the initial design to getting them on the shop floor ready for machining, has a significant effect on delivery times to Bri-Stor and subcontract customers, which in turn, improves our profitability.

"We're currently pushing towards automation, high efficiency, and lean manufacturing. The focus of this plan is on utilising high-tech machine automation to realise a 'smart factory' vision. Now, close to £4 million has been invested to secure Alpha's position as one of the most technically advanced factories in the industry. The Stopa storage system is a major part of that and RADAN plays a vital role with quick, powerful automatic nesting and good sheet utilisation.

"We have a standard procedure that every sheet we nest must be utilised to a minimum percentage. And we achieve that, thanks to RADAN."

Hexagon Manufacturing Intelligence

Tel: 01242 542040

Email: enquiry.uk@hexagonmetrology.com

www.hexagonmi.com



Machine-optimised ESPRIT CAM Solutions for Willemin-Macodel

Willemin-Macodel is a supplier of cutting-edge, made-to-measure machining solutions for complex, very high precision workpieces offering high added value in industries like watchmaking, jewelry, medical, aviation and more.

Due to the innovative configuration and complexity of certain millturn machines, 508MT, 508MT2 X400, 408MT, programming and simulating using conventional Computer-Aided Manufacturing (CAM) software can be a challenge. Without the right software to drive those powerful machines, it is difficult to fully utilise their capabilities and realise their complete benefits.

By working directly with Willemin-Macodel and a number of key clients, DP Technology engineers developed highly optimised support for Willemin-Macodel within their ESPRIT CAM software to drastically improve the user experience and programming efficiency for the MT series, including output of machine-optimised, edit-free G-Code.

Some of ESPRIT's key capabilities for these machines include the ability to create

and sort operations in the required work coordinates, optimise simulation to match the output NC code and actual machine behavior and display various operation information to make programming in ESPRIT easier. Providing a simple interface to set global machine settings and offering an easy way to mount vise jaws on the turret with a quick solution to mount chuck and collet on the main and sub spindles.

Well known in the industry for generating edit-free G-code, DP engineers also worked closely with Willemin machine specialists to create a turn-key digital machine package, consisting of post processors and virtual machines for the MT series. This eliminates the time spent on editing the G-code and streamlines the machine setup and first article run off for the end users.

"ESPRIT post developers collaborated with the team at Willemin-Macodel to develop a WM-specific software solution that enables quick processing of complex parts on our full 5-axis mill-turn machine

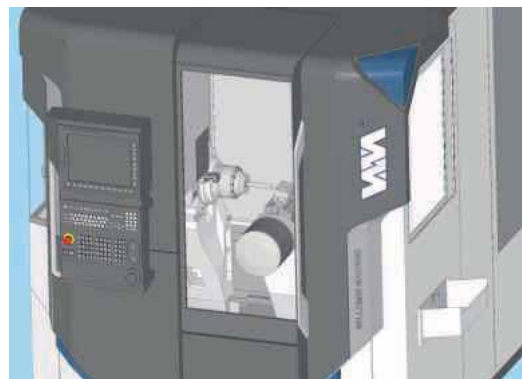

tools," says Jim Davis, application manager at Willemin.

ESPRIT provides not only a dedicated CAM solution for the Willemin-Macodel machines, but also extensive engineering expertise and knowledge to make sure the end users get started quickly and keep running at top efficiency using the MT series machines.

ESPRIT CAM Ltd

Tel: 0151 632 3415

Email: chris.edwards@dpotechnology.com

www.espritcham.eu

Gc GibbsCAM®

MULTI-TASK MACHINING



GibbsCAM delivers many new capabilities to improve and accelerate every part of the programming process, taking parts from concept to creation in record time.



Tech CAD/CAM - GibbsCAM UK distributor since 1997

☎ 01284 754781 🌐 www.techcadcam.net ✉ info@techcadcam.net

Tebis Version 4.0 Release 9 with machine technology

CAD/CAM and MES specialist Tebis has announced the latest release of Tebis Version 4.0 Release 9. The new release implemented numerous advanced functions to automate everyday CNC machining CAM tasks and improve productivity, quality and safety.

CAM automation

Flexible NC programs with bore patterns Element selection in feature machining has been extended, allowing the user to select features in the same tilt direction and plane and with the same dimensions and NCSet. This allows the output of NC programs to be more flexible in modifying the drilling positions in the control.

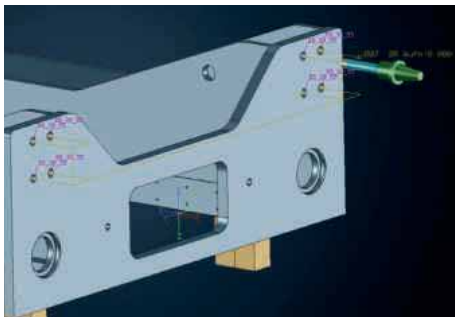
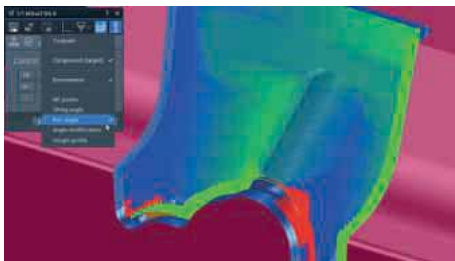

Automatically detect spot face depth

Machining of bores and standard pockets are more simplified. The spot face depths can also be automatically determined when scanning features.

CAM milling - reliable milling by accounting for the machine head

With the new Tebis release, the user can generate collision-free toolpaths even more easily. The head or the table can be turned interactively within the bounds of the machine's kinematics to better access the milling areas during calculation, a significant advantage for asymmetric heads. This is especially useful for 5-axis machining.

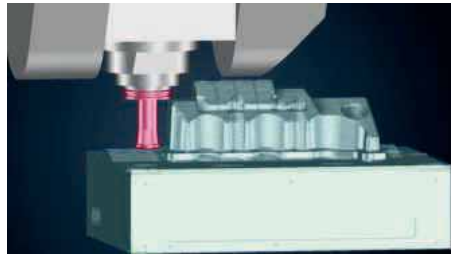

Finish contours with radius correction with downward machining

A new strategy is available for downward machining on contour finishing. This can also be combined with roughing in an NCJob and also generated with radius correction.

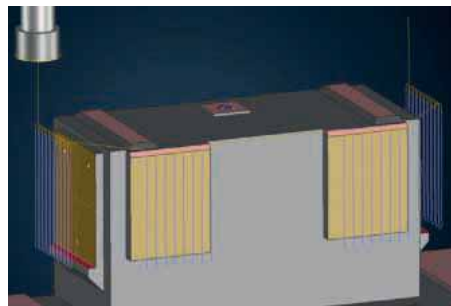

Faster completion with separate offset values

An additional axial or radial allowance can be assigned to enable roughing with a different allowance in flat and steep areas.

Best surface quality with 3- to 5-axis machining

Machine the best surfaces with the 3- to 5-axis collision avoidance strategy. The positions of the rotational axis are now better synchronised for adjacent toolpaths. The tool also pivots more smoothly to the new tilt direction in corners. The new analysis function in interactive calculation can be used to evaluate the tilt angle of the A/B axis, the rotation angle of the C axis, the change in angle per path and the height profile before manufacturing surfaces at top quality.

CAM Lathe - improved cutting data management for turning tools

The improved cutting data management for turning tools can be automatically applied in contour turning and downward machining. This always allows to use the best cutting

data on each machine group for each material and each machining type.

Reliable turning calculations with the tool carrier

Collisions avoidance with the tool carrier and this enables fast and reliable calculation of NC programs, even for complex machining operations.

CAM machine technology - more machining options with free-rotation axis

Collisions can be prevented with a different head rotation, the kinematics configurations of the virtual machines can be used to set the rotation axis with a degree of freedom at the desired value.

CAQ measure - increased productivity thanks to measurement integrated in the process

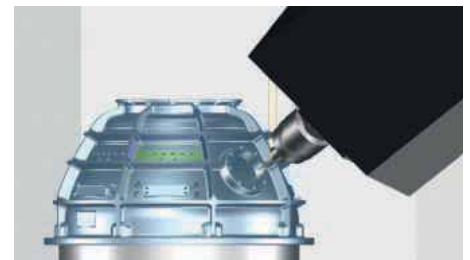

Completely integrate your measuring tasks in the manufacturing process easily and with reliable collision protection. Integrated tolerance testing can be performed to determine whether the order can continue to be machined or must be interrupted. This results in a reliable and highly automated process with combined milling, turning and measurement operations that prevent damage to tools and machines. This results in a shorter setup and machining time, higher component quality and fewer correction grinding operations.

Tebis (UK) Ltd
Tel: 02476 158178
Email: info-uk@tebis.com
www.tebis.com/en

Battery Ventures acquires Cimatron and GibbsCAM from 3D Systems

Battery Ventures, a global, technology-focused investment firm, has agreed to acquire the combined Cimatron and GibbsCAM software businesses from global additive manufacturing solutions company 3D Systems Corporation. The transaction is expected to close during the fourth quarter of 2020, subject to customary closing conditions.

As part of the acquisition, Cimatron and GibbsCAM will join Battery-backed SigmaTEK Systems*, a CAD/CAM software provider serving professional fabricators, in a new holding company called CAMBRIO. Headed by Robbie Payne, current SigmaTEK Systems CEO and a veteran tech executive, CAMBRIO will leverage Cimatron and GibbsCAM to offer a diverse set of design and machining software solutions, and firmly position itself as a CAD/CAM innovator in the fabrication, toolmaking, and production machining industries.

Current SigmaTEK Chairman Richard Smith, previously CEO of Vero Software, a UK-based CAD/CAM software maker acquired by Hexagon AB in 2014, will join

CAMBRIO's board, along with Steve Sivitter, another former Vero executive who is currently the CEO of 1WorldSync, a product-content solutions company whose software helps large brands share product data with retailers, operators and distributors.

"We are extremely pleased for the companies to be combining forces. It is a great strategic match," says Richard Smith. "The teams have proven track records and we can leverage our extensive domain expertise in manufacturing software to drive product development and benefit our customers like never before."

Commenting on the acquisition, Robbie Payne says: "We are often serving the same customer profile and trying to solve similar industry issues with innovative software technology. As a combined entity, we will continue to invest in each of the individual products, make our customers more productive, and enlarge our distribution capability. Finally, we are excited about working with the existing Cimatron and

Battery

GibbsCAM employees and partners and look forward to further expanding our presence in the global market."

SigmaTEK Systems provides robust CAD/CAM, nesting, and automation software solutions for every size business, from new job shops to established manufacturers. Since its founding in 1993, it has been dedicated to research, development and extensive support for products, including SigmaNEST, SigmaTUBE, SigmaBEND, SimTrans and SigmaMRP.

SigmaTEK Europe Ltd

Tel: 02476 982299

Email: sales@sigmanest.com

www.sigmanest.com

Free access to component CAD drawings speeds up design

Fast and simple access to component part CAD drawings is vital for engineers to design machinery. Accurate 3D visualisations also help buyers make quick decisions. WDS Components Ltd freely presents its library of 20,000-plus product drawings in a variety of CAD and non-specialist file formats to help component users speed up their design process.

Computer-Aided Design, better known as CAD, is used today throughout all industries to increase the speed and reduce the cost of design. While an engineer uses CAD on a daily basis to develop new designs or make modifications to existing developments, it's vital that they have access to CAD files of the component parts used on their design.

3D CAD drawings improve the quality of design with the ability to create an accurate model to guide development. They increase the speed of development, removing the need to wait for actual product samples before integrating them into designs and increasing time to market. They also reduce the cost of development, removing the



need to procure a variety of components before identifying the right specification. CAD models are of course also required when specifying components and standard parts in industries including aerospace, automotive and rail.

A choke point for the design engineer is often the access to the files they need. Most significantly, this includes the availability of drawings, which may not cover the entire product range, or may not include the full selection of items, such as different sizes within a component product family. For this reason, WDS presents virtually its entire range of components in CAD format,

including products such as toggle clamps, gas struts and cam levers, amounting to over 20,000 drawings.

To improve the ease and speed of access to CAD files, WDS includes the entire library free of charge on **www.wdscomponents.com**. With no cost and open access, as many files as required can be downloaded. To save time for the customer, only a single log-in is needed to access and download the library as opposed to making a specific request each time a CAD file is required.

WDS has identified that on some websites, CAD download speeds can be notoriously slow. By uploading the 20,000 strong CAD file library to its servers, WDS has removed this problem, guaranteeing fast downloads and removing any 'lag' from the process.

WDS Components Ltd

Tel: 0113 2909852

Email: sales@wdscomponents.com

www.wdsLtd.co.uk

ProdOpti cut hard materials in full 3D with abrasive waterjet from Water Jet Sweden

ProdOpti is a rapidly growing company with broad expertise in the manufacturing industry. By investing in knowledgeable staff and a modern production facility, its client base has rapidly grown and turnover has multiplied in recent years. For continued development, ProdOpti has invested in a new machine from Water Jet Sweden. With a "FiveX" waterjet machine, ProdOpti is today able to offer abrasive waterjet cutting in full 3D, with a comprehensive 3D Cad design service.

"ProdOpti should always be the company that is at the forefront of machining. To live up to this, we invest in modern equipment to meet the demands of the market." says Gabriel Öfverberg, CEO of ProdOpti. "Our business was awarded to Water Jet Sweden's FiveX machine as it is, with modern 3D technology and it's pipe cutting unit, the most flexible water cutter able to produce products in both small and large volumes."

ProdOpti should be used if you are looking for high quality and short lead times. That requires machines with great flexibility and advanced sustainable technology combined with knowledgeable staff.

"At ProdOpti everybody is welcome. You might have a small idea you would like to realise, or you might need large volume production", says Gabriel Öfverberg. "We adapt our service to demands in order to give our clients what they want, and sometimes we can help to improve the idea to something even better. A "FiveX" machine gives us great opportunities to deliver a final product that exceeds the customer expectations. We want to show that most things can be produced with machining, and it does not have to take several weeks to deliver the final product."

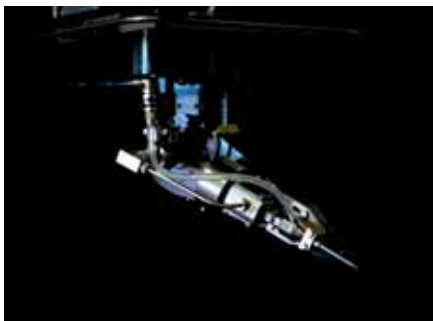

"FiveX is a machine model used in several high-tech industrial sectors, such as the aircraft industry. The machine is built with our most advanced technology. It has an extremely stable frame design to be able to manufacture 3D components in hard materials with very high precision with positioning accuracy of ± 0.050 mm/m."

The machine ProdOpti ordered is 4.2 m wide and 6.7 m long, giving a worktable of 28 sq m. That size is not unique in itself, but with a Z-movement of 1.2 m you get a cutting space of 33.7 cubic m. This makes it one of the largest "FiveX" machines that has been manufactured so far.

FiveX is the only cutting head in the world with a $\pm 120^\circ$ movement enabling it to process 3D parts with abrasive waterjet technology. This is also the reason why the FiveX model is equipped with solid safety walls all around the cutting space. The front wall opens and closes automatically from the operator panel. Around the machine there are small windows made of safety glass so the operator can monitor the cutting visually, together with the possibility for remote monitoring by camera.

On the back wall, ProdOpti has chosen to install a rotary unit for machining pipes and springs. With the rotary unit located at the back of the machine, the entire machine length can be utilised for machining up to 6 m long pipes.

To reduce the sound level and water splashes, ProdOpti has added the ability to cut under water. The surface of the 23,000 litre water tank can quickly be raised or lowered by 80 mm, just by the touch of a button. ProdOptis FiveX machine performs



everything from efficient 2D cutting to highly advanced cutting in full 3D, all at very high precision.

Water Jet Sweden offers an extensive product portfolio of waterjet systems for wide range of manufacturing needs. From small, fine mechanical to large aerospace and ship components. Its native town of Ronneby in southern Sweden has become a R & D cluster of global renown, where the scientific establishment, the waterjet industry and the business community join efforts to develop the waterjet cutting technology of tomorrow.

WJS UK Ltd
Tel: 01937 845499
Email: info@wjsuk.com
www.waterjetsweden.co.uk

DISCOVER WHAT AN OMAX ABRASIVE WATERJET CAN DO FOR YOU!

OMAX Waterjets streamline operations by reducing your need for multiple machines, secondary processes and extensive employee training. OMAX Waterjets are the perfect complement to your shop. The flexible tool cuts like a saw, machines like a lathe, contours like a mill, shapes like a wire EDM, and forms like a broach. Learn more today.

**CUTS STEEL,
ALUMINIUM, GLASS,
FOAM, RUBBER,
CARBIDE, STONE
AND GRANITE**

**EASY
FIXTURING**

**USER-FRIENDLY
SOFTWARE**

OMAX@OMAX.COM • WWW.OMAX.COM

FOLLOW US    

 **OMAX**® ABRASIVE WATERJETS

Processing fibre composites made easy

Why water as a tool and STM waterjet systems are the best practice solution for processing sensitive composite materials

Fibre composites such as CFC, CFP, GRP and carbon are enjoying ever more interdisciplinary popularity thanks to their formability, corrosion resistance, stability and lightness. Especially in lightweight construction and space travel, production must be adapted accordingly. This increases the need for delicate all-purpose cutting processes, as composite materials fray easily and their mechanical material properties such as heat resistance, radiation absorption or fire resistance can be easily impaired during cutting.

In addition, the dust generated during machining must be discharged as it is harmful to health and, as an electric conductor, can also damage the machinery. There is a simultaneous requirement for high precision and flexibility for machining. These high demands put the spotlight on one tool technology: waterjet cutting.

This is because the cold-cutting technique enables highly delicate working and cuts even the finest and most complex structures accurately, reproducibly and virtually fully automatically with tolerances of +/- 0.3-0.1 mms. Thanks to the very thin die clearance of 0.8 mms, this technology is not only fast and cheap but also delivers high material efficiency with minimum tool wear. Reworking of frayed areas is not necessary. Likewise, in contrast to thermal cutting techniques, neither hardening or tensions

on the workpiece nor harmful steam, dust or smoke occur during the cutting process, since cutting can also take place under water.

All in all, waterjet cutting is an environmentally friendly and inexpensive way to cut all customary composite materials. Unlike milling, almost all other materials can be cut on the same machine without much time-consuming retooling while the water used can be treated and reused. These requirements are met by the waterjet cutting systems of STM.

With its modular system, the Austrian waterjet pioneer specialises in customised complete solutions and offers interested companies a full service perfected down to the last detail. The range of services covers consulting and test cuts, training courses, service and maintenance right down to the comprehensive supply of wear parts and operating resources and financial management. With this all-round support, STM provides an opportunity to switch to new, more efficient technology. The best examples are the carbon processing waterjet users, tfc tools for composite GmbH and 3c-Carbon Composite Company GmbH.

STM's waterjet system can cut composites efficiently and its modular waterjet cutting system can be individually adapted to current requirements. The Austrian



company has been specialising in the universal and economic implementation of waterjet technology for over 30 years. Even with inexpensive entry-level models, such as the STM EcoCut, in principle any composite material can be cut on one and the same machine with either pure water or the addition of abrasive sand and without the need for time-consuming retooling. At the same time, the pressure can be continuously adjusted to match the material properties. With soft composites, the working pressure can be throttled down to 600 bar during drilling, while with harder materials, cutting can take place using pressures up to 4,000 bar. With the high-pressure pump, functions such as frequency converter and soft start ensure energy and cost efficiency and environmentally friendly operation.

Programming cutting tasks takes only a few minutes with the intuitive STM SmartCut software. Drawn workpieces are scanned by the software and nested in the best possible way for larger lot sizes. From this point, a fully automated cutting process starts up.

Possible additional system equipment such as a pneumatic drilling spindle for drilling sensitive materials or the OneClean modular water treatment system are available as options for all systems and can be retrofitted at any time at a later date.

Companies can grow with new tasks without friction losses, since STM's modular system provides a practical solution for almost any cutting challenge. The possibilities go far beyond the processing of composite materials and include materials such as steel, aluminium, metal, stone, ceramics, plastic and glass.

STM Stein-Moser GmbH
Tel: 0043 6458 20014832
Email: info@stm.at
www.stm.at



Flow is proud to invite you in its Flow Technology Center



Flow International Corporation, the world's leading developer and manufacturer of industrial waterjet machines is pleased to introduce you the new Flow Waterjet Technology Center in Douvrin, North of France, next to major cities and international airports (1 hour from Paris). The Technology Center expands the customer training and application engineering lab at a new 7,000 sqm facility.

It provides world-class waterjet training in new classrooms. It is also equipped with a waterjet lab to be used for training customers on maintenance, software, advanced applications and more. Alongside the training classrooms is a fully-equipped applications lab which includes each of Flow's Mach series line of waterjet systems: Mach 100, Mach 200 and two Mach 500 (Dynamic Waterjet and Dynamic XD Waterjet).

In addition to this, Flow is equipped with the latest digital technology to offer you remote demonstrations given the current circumstances. You can at any time request a virtual tour of the installations, a live cutting test on your own material or a demonstration of the capabilities of the various machines on display.



Flow International Corporation is a global technology-based manufacturing company committed to providing a world class customer experience. The Company offers technological leadership and exceptional waterjet performance to a wide-ranging customer base, benefiting many cutting and

surface preparation applications, delivering profitable waterjet solutions and dynamic business growth opportunities to our customers. For more information, visit www.FlowWaterjet.com.



CAN'T CUT THIS?

Cut any material and any shape with a single equipment

Flow's waterjet cutting equipment performs a perfect cut on any material (wood, acrylic, plastic, armoured glass, marble, granite, stainless steel, carbon, aluminum, titanium, rubber, cork, nylon etc.) with excellent finishing, no tool change, just choose a new material from the software library.

With Flow water jet it is possible to cut any design, even the most complex ones with richness of details and in the most varied thicknesses and with great finishing.

Contact us and know the options that we have to meet your company



Flow UK : www.FlowWaterjet.com
Unit 3 Canton House
Wheatfield Way, Hinckley, LE10 1YG UK
Office: +44 1455 895 300



OMAX provides the gateway to industry success

Fogo Island Inn, New York Yankee Stadium and the Shangri-La Hotel: these are just a few extraordinary projects produced by the glass architectural and design-focused Central Canadian Glass (CCG). Its large shop highlights an all-in-one method of production where fixturing, stonework and metal are cut alongside glass. Committed to providing its clients a product of the highest possible quality with the best turnaround time, the Concord, Ontario-based fabrication shop has earned the right to be called an industry leader in custom glass.



Shangri-La Hotel, Vancouver Canada

CCG started in 1988 with four people: "Glass is the last product you need in a construction project," says Pat Trainor, president of Central Canadian Glass. "Once the area for the glass is measured, they need it. Our growth was driven by lead times. We decided to go with technology to build our business." Over the years, CCG utilised progressive glass cutting methods to give them a competitive edge when introducing new products to market. Today, the company now has 55 employees and a 3,700 sq m facility that contains

state-of-the-art glass fabricating equipment operated by experienced craftsmen.

One of the primary innovations CCG made over the course of its 31 year history was integrating OMAX abrasive waterjets into its workflow. All OMAX product lines can be used for cutting a wide variety of glass products, from ultra-thin panels for smartphones to thick multi-layered bullet-proof panels for vehicles and buildings to panels for stained glass windows. There are some inherent issues with machine cutting glass, OMAX resolved these challenges by introducing low-pressure piercing. Now, even the most brittle glass can easily be pierced to create a starting point, yet still be cut at maximum speed.

Pat Trainor recalls his first meeting with OMAX: "Years ago, an OMAX salesperson walked into our office making a sales call. I asked, 'What is the best thing about OMAX?' The salesperson responded, 'the people.' It was at that point I knew that OMAX would make a great partner." CCG has been a customer for years, utilising customer service and support to ensure their machines are always making money. The Kent Washington Team, as well as local distributors, Spark & Co, back up the promise of attentive assistance whenever CCG calls. Pat Trainor adds: "I know what my time is worth."

In January of 2014, CCG purchased a MAXIEM 2040 JetMachining Centre. Designed for shops with high-capacity production demands, the MAXIEM 2040 abrasive waterjet system can easily machine almost any material. Pat Trainor explains: "Cutting with our waterjet allows us



accuracy and repeatability." The MAXIEM line showcases a linear accuracy of 0.762 mm and a repeatably of 0.025 mm for remarkable precision.

Beyond precision, the MAXIEM helped improve CCG's productivity. "Something that was a one- or two-week job, we do in one or two hours," he continues. CCG is renowned for its ability to put out great quality work when the customer requires and the company purchased a second MAXIEM 2040 in 2015.

The fabrication shop primarily cuts 3-19 mm glass and mirror. However, as Pat Trainor explains: "Since we've introduced OMAX, it has got us into so many different industries. We're into everything now: glass, metal, stone, you name it, we cut it with a waterjet. The diversity of what we can offer is key. A lot of contractors, architects, designers don't want to run all over the place getting this here or that that there. They come to us."

The ability to diversify has allowed Pat Trainor and CCG to cut for a wide variety of industries including recreational vehicles, mining equipment, store fixtures and mill work. "We're very diversified," adds Pat Trainor. "If one side of the business is slow, we have another the marine business or the RV business."

For over thirty years, CCG has done nothing but grow. From customer glass fabrication, to a wide array of markets, the technology the shop has adopted helped to create a thriving business.

UK Agent:
Aquajet Machining Systems Ltd
Tel: 01257 248480
Email: sales@aquajet.co.uk
www.omax.com



AAG supplies latest WARDJet waterjet cutting system to Lionweld Group

Telford, Shropshire-based AAG has supplied a WARDJet waterjet cutting system to Middlesbrough, North Yorkshire-based Lionweld Group, a leading manufacturer of forged steel and GRP products, including safe grid flooring of which it is the sole UK producer. It supplies to the offshore wind turbine, nuclear energy, rail and hydropower sectors. Following its acquisition by AAG's parent company in Canada, U.S.-based WARDJet is now a division of AAG, with WARDJet waterjet cutting machines now complementing the well-known family of AXYZ CNC routing, cutting and finishing systems.

The machine installed at Lionweld Group is the X-2040, one of three different-sized models in the X-Series of large-format ball-screw WARDJet cutting systems, all of which provide a maximum cutting speed of 20 m/min. The machine incorporates additional design features that include a special height sensor, a 400 lb, 181.437 kg, capacity continuous abrasive feed hopper

and a 60,000-psi intensifier pump. Optional machine enhancements that can be installed on the machine include a water level control system, cutting table enclosure and the latest Apex-60 5-axis cutting head for radically enhanced 3D cutting performance.

The X-2040 is powered by WARDCAM design and production software supplied by AAG. In addition, Lionweld Group also uses specially designed software required to nest the several parts of its standard 3.6 x 1.2 m GRP mesh panels.

The X-2040 was purchased initially to complete an order for wind turbine internal platforms that required these mesh panels but in the longer term to provide a more efficient waterjet cutting capability to that already available on an existing machine installed at a sister company. Engineering manager at Lionweld Group, Richard Hookway explains: "Previously, these platforms were constructed manually by two engineers and required approximately two weeks to construct each platform, thus proving labour intensive, leading to longer



turnaround times and increasing the risk of errors in production. Following installation of the X-2040 machine, it now takes less than a day for one employee to achieve the same result. Furthermore, by comparison with the waterjet machine already in use, the X-2040 has also proved much simpler to operate and easier to maintain."

"The X-2040 has been a great addition to our machine portfolio, with the consequent increase in cutting speed and accuracy a real boost to our production capacity and manufacturing capabilities."

AXYZ Automation (UK) Ltd
Tel: 01952 291600
Email: enquiries@axyz.com
www.axyz.co.uk

Passion for precision

With over 30 years experience in waterjet cutting our passion for precision, development & quality is unparalleled.

We offer bespoke machine designs & with our market leading service & support are with you every step of the way. Let us help find the right solution for you. Call us on 01937 845 499.

Devoted to performance

WJS
WATER JET SWEDEN

WJS UK Ltd, Moat House Square, Thorp Arch, Wetherby. waterjetsweden.co.uk

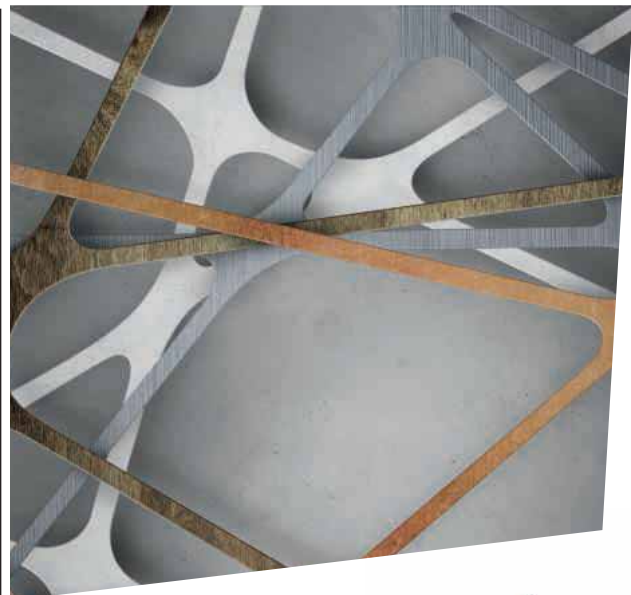

We think
 one cut ahead.

Waterjet cutting system by StM.
stm-waterjet.com



Waterjet solutions

T&T Tubecraft invests in Unison's ultimate CNC tube bending machine

Tube manipulation and pipe bending subcontract business, T&T Tubecraft has taken delivery of a new all-electric 130 mm diameter multi-stack CNC tube bending machine from leading tube manipulation technology specialists, Unison Ltd.

This is the third Unison tube bender to be purchased by T&T Tubecraft since 2014. It joins a 50 mm Unison Breeze machine and a 100 mm Unison Breeze multi-stack model that are in daily use at T&T Tubecraft's Woking-based facility. Offering exceptional power and immense levels of flexibility, the 130 mm machine has been described by Unison as 'the ultimate tube bending machine for subcontractors'.

"Of all our tube benders, our 100 mm Unison machine is easily the busiest," says T&T Tubecraft managing director Ross Turner. "This is largely down to its user-friendly programming, fast tool changes, automatic setup and uncompromising levels of accuracy and repeatability. Ironically, when we purchased the 100 mm Unison machine back in 2015, we didn't have a vast amount of work for it. This quickly changed, however, as we gained the ability to take on new projects. The new 130 mm machine will increase our capability even further, both in terms of capacity and the ability to tender for an even greater range of projects. We expect it to be of particular interest to customers in the aerospace sector."

The bigger brother of the Unison 100 mm multi-stack machine, the Unison 130 mm tube bender purchased by T&T Tubecraft is particularly suited to bending exotic alloys such as titanium and Inconel, as well as Super-Duplex stainless steels. Able to push bend tubes of up to 6.2 m in length when in standard mode, it also features a hitch-feed facility, whereby the machine carriage retracts by the length of the next feed, enabling mandrel bending of tubes of up to 8.7 m long. As a result of this capability, T&T Tubecraft believes that, out of all UK tube manipulation subcontractors, it may provide the longest bending range.

Multi-stack tool holding allows the most complex of parts to be formed in one uninterrupted manufacturing cycle, while Unison's bar code scanning system ensures that only the correct tools are installed while also configuring the machine automatically. A further feature which attracted T&T Tubecraft to the Unison 130 mm machine is

advantages over hydraulic machines," continues Ross Turner.

"Bending accuracy and repeatability are dramatically improved. We achieve right-first-time manufacturing for repeat subcontract work and typically expect even the first bent trial component at the start of a project to be very close to what we are



the standard-fit rise and fall pressure die. This can result in significant savings in tooling costs and allows tools of very different radii to be used on a part within a cycle. Like all Unison machines, T&T Tubecraft's new 130 mm machine is also highly powerful.

"This is a significant advantage for us, as it provides the reassurance to achieve high quality thin wall bending, even on high yield-strength alloys such as Inconel," adds Ross Turner.

The 130 mm machine has been networked to T&T Tubecraft's CAD facilities and a Coordinate Measuring Machine (CMM) for verifying bend accuracy and design conformity. The tube bender can be programmed manually or from CAD data using industry-standard IGES or STEP files, while data obtained by the CMM from the first manufactured part can be used to make automatic adjustments to the machine prior to commencing a manufacturing cycle.

"The all-electric architecture and automated Unibend software-controlled setup of our Unison machines offers major

looking to achieve. Machine configuration is also rapid, typically only taking 15 to 20 minutes. As a subcontract tube manipulation company, we also quickly get to hear how well new machines are viewed by our teams. Unison machines are very well received by our workforce. Unison's Unibend operating software is exceptionally intuitive, meaning much faster programming and accelerated training for new staff members. Our operators consider the Unibend control system to be exceptionally user-friendly."

"It is always satisfying to receive repeat orders, especially when they are from such a well-respected company as T&T Tubecraft," adds Unison key account manager, Steve Haddrell.

Unison Ltd
Tel: 01723 582 868
Email: sales@unisonltd.com
www.unisonltd.com

Safely separate steel sheets with special magnet

The fail-safe sheet separator recently developed by Goudsmit Magnetics provides automatic separation of steel sheets up to a thickness of approximately 4 mm. The separator is equipped with very powerful neodymium magnets and can be switched on and off pneumatically using a new patented system.

This switching is done quickly by rotation of the magnets. The maintenance-free sheet separator is the only one of its kind with a spring-actuated off position. The extremely safe sheet separator automatically switches to the off position even if the compressed air supply is interrupted, even at full load and at maximum stacking height. The magnet cannot accidentally remain switched on during maintenance either. That's something you ordinarily cannot see and it can lead to industrial accidents. With the red indicator you can see from a distance whether the magnet is switched on.

This provides extra safety. In contrast to fixed sheet separators, switchable sheet separators also allow interim changeover of products during a set process. It is possible

to separate steel sheets of almost any shape, length or width, even round and asymmetrical shapes. The permanent magnetic force does not degrade and is guaranteed for decades.

In combination with the swivel arm, this system is also height adjustable. Magnetic sheet separators are used in sheet processing industries and in robotised production cells for the production of welded assemblies. Robots use magnetic grippers to pick up large sheet metal parts and position them on a welding table. Because the steel sheets are oiled, they stick together and the robot occasionally picks up two sheets at the same time. As a consequence, the second steel sheet may release halfway across the welding table and fall. This causes tremendous damage in high-tech environments, where the welding table is often equipped with sensors, transducers and actuators. Moreover, the double insertion of two steel sheets that are stuck together can cause extensive damage to a die. Through the use of neodymium sheet separators, the sheets are separated

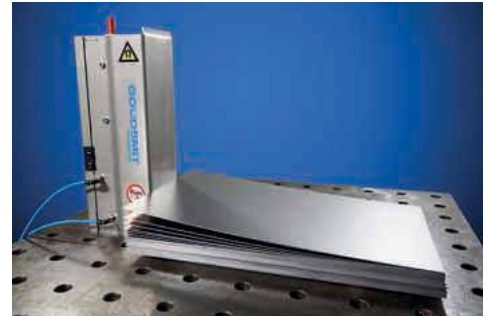

from each other despite the oil film, after which the robot can lift them from the stack, one at a time. The fail-safe sheet separator also has the option of on/off detection by means of a pluggable plug & play system.

The compressed air-operated sheet separators increase safety and reduce costs when stacking or changing stacks of steel sheets.

Goudsmit Magnetic Systems BV
Tel: 0031 40 221 3283
Email: info@goudsmitmagnetics.com
www.goudsmitmagnetics.com

Innovation and sustainability combined

Technology company transfluid has for many years been offering machines to cut tubes, in addition to machines to bend and form tubes. "There is always a cut before a bending and forming process, so it was a logical step for us to offer this option to our customers", explains Stefanie Flaeper, sales and marketing director. "The strong demand in this area has confirmed this and driven the development of our machine technology."

The sustainability starts with the technical equipment and includes the quality of the cuts. The robust build of the machines makes the tube cutting machines from transfluid durable and timeless. The cutting results are impressive and the tubes can be used without further deburring, depending on the requirements. Setting up the machine is easy, making it quick to make the changes for different tube diameters. The performance is around 1,800 cuts/hour, depending on the length of the section and the diameter of the tube.

The transfluid t cut machines also have

very efficient peripherals, which make it possible to process, for example, small numbers with a loading table or as bundles with automatic feeding and separation. Tube processing straight from a coil is also possible, of course. Accurate straightening devices ensure that the tubes are perfectly straight.

The sorting of the tubes that have been cut can be done with different removal devices, they are grouped and removed at four or eight positions. If necessary, each individual tube can be labelled, to make sure that the tube is identified correctly at each stage of the process ahead. When very long tubes are used, which are longer than the magazine, it is possible to use automated nesting with these machines. This means that when the machine is fed enough length and number of pieces, the tubes are cut with the minimum amount of waste.

The cutting process is done with cutting blades with an orbital movement. Throughout the process, the tube is pulled



in a controlled manner from both sides at the cutting position and pulled apart at the appropriate time. This means most of the cutting is done with a rotating blade and the last few hundredths of millimetre of tube thickness are pulled apart while the blade is still operating.

transfluid Maschinenbau GmbH
Tel: 0049 2972 9715 8700
Email: sales@transfluid.de
www.transfluid.net



A new generation of wire feeders and inverter-based power sources combines portability, durability and performance

Technology advances mean it's time to re-evaluate your wire feeder

By Paul Woodford, marketing & aftersales manager UK & Ireland, ESAB Welding & Cutting Products

MIG/MAG, pulsed MIG and flux cored welding requires smooth feeding performance, ease of operation, control over welding variables, durability and, in many situations, portability. Recent technology advancements encourage a reassessment of how choosing the right wire feeder could contribute as much to your bottom line as choosing the right power source.

A new breed

Whether on a shop floor, ship or construction site, portable equipment that puts the feeder closer to the welding location helps operators complete work faster and with greater precision. "Shop feeders" offer excellent feeding performance and additional controls but have limited protection in extreme environments. Portable feeders offer mobility and durability in harsh conditions but have limited functionality. Now, these two categories have merged into a third category: the advanced portable wire feeder that combines performance, portability and durability. This article highlights attributes users can now find in portable wire feeders, such as ESAB's new Robust Feed series and links them to how they improve operations.

Wire feeding performance

Feeders such as Robust Feed, with a four-roll system, double the amount of drive roll surface area in contact with the wire. Larger diameter drive rolls also increase wire contact area, as does drive roll groove design. More gripping area enables feeding without deforming the wire through longer torch cables, bends in the cable and even with softer cored and aluminium wires. A good four-roll system allows you to run larger diameter, up to 2.0 mm solid wires and 2.4 mm cored wires and smaller diameter, 0.6 and 0.8 mm, hard wires, as well as weld at speeds as low as 0.8 m/min and as fast as 25m/min.



With its four-wheel drive stand, large drive rolls and unique drive mechanism, Robust Feed delivers feeding performance that surpasses that of premium shop feeders

Advancements have resulted in controlling the drive motor so that it's driven

in two directions. This provides incomparable feeding performance during starts, at lower speeds and enhanced control of the wire speed overall. This type of drive stand is actually suitable for a robotic system but is now available in portable units, which is a major development.

Enhanced controls

Quality issues occur most frequently at the start or end of the weld, so advanced portable feeders, such as Robust Feed U6 and Robust Feed Pulse, offer a host of functions to improve results.

Run-in speed control, also called creep, reduces the speed at which the wire approaches the plate, then ramps up to full welding speed when the system senses the arc is established. Wire feeders with a crater fill function ramp down parameters at the end of the weld to fill the crater at a lower wire feed speed and/or voltage level, which can prevent crater cracking and avoid melting the edges of the plate. Gas pre-flow and post-flow control enable the operator to set the duration of gas flow times, helpful in applications where gas coverage is critical, notably stainless steel.

Short Circuit Termination (SCT) technology sharpens the end of the solid

MIG wire at the termination of a weld to promote a positive next arc start. A burnback function controls the amount of wire that continues to feed after the operator releases the trigger so the operator does not need to clip the wire to length. On feeders with 2T/4T control, the 2T mode is for standard On/Off operation. The 4T, "trigger hold", feature is like cruise control for the welder.

Operators won't waste time adjusting settings for different jobs. Advanced wire feeders such as Robust Feed U6 and Pulse offer memory settings that enable operators to set, store and recall more than 90 sets of parameters with the push of a few buttons.

Advanced controls

Advanced feeders offer some additional functions that improve quality and consistency. For example, preprogrammed synergic lines have optimised parameters for the wire type, wire diameter, shielding gas and process selected, speeding set-up, and a limit function prevents the operator from welding with parameters outside of weld specifications. A function called "quick set" automatically optimises the short circuit arc for the gas/wire combination installed to

match an operator's individual welding style. Synergic lines for pulsing MIG can save many hours of process development time. Operators simply select the synergic line to achieve optimum dynamic arc control.



Robust Feed's advance capabilities help less experienced or moderately skilled welders produce better results and can transform good welders into great welders

Many facets of portability

Weight is one aspect of portability but also consider that feeders with handles on the front and back of the unit are significantly easier to lift with two hands, as well as pass through a manhole or small opening.

For lifting feeders with a crane, look for units that have crane-rated handles. Operators are also going to move the feeder by sliding it along the floor or dragging it by the cables and feeder case

designs with reinforced walls and built-up wear areas will last longer. Even better, use a wheel kit to eliminate dragging.

Wire feeders in heavy industrial environments take a beating. The Robust Feed series have an IP44 rating, meaning that all sensitive components are protected against solid objects that are bigger than 1 mm and water splashing from all directions. They are literally sealed against weather, dirt, metal shavings and other contaminants. Note that IP44-rated feeders also have the option for an internal heater kit to protect against moisture.

If your current wire feeders do not have a majority of these features and benefits, it might be time to re-evaluate your equipment. Such feeders minimise maintenance headaches promote both uptime and better weld quality and help increase operator skill. They also help standardise training and wear parts inventory, all of which lead to greater profits.

ESAB Group (UK) Ltd
Tel: 01992 768515
Email: service@esab.co.uk
www.esab.co.uk

New Master 315 adds extra to the ordinary

Kemppi has announced the launch of a new welding machine for MMA welding: Master 315. This machine includes several new features that add something extra to ordinary MMA welding. Exciting new features promote usability and personalisation, but the main benefits of this machine still come from its excellent welding quality.

Master 315 is a stylish and practical machine for a workshop or on-site use, capable of absorbing the knocks and impacts of everyday welding life. Lightweight and compact, Master 315 is constructed from tough injection-molded plastic, featuring impact bridge protection structures.

Master 315 lets you enjoy the magic of cordless remote control. With the HR45 Bluetooth hand remote unit you can control the welding power and select memory channels from a distance of up to 100 metres. This device eliminates the need for remote cable repairs and improves worksite safety.

Master 315 comes ready-equipped with a

full-color 7-inch TFT display, where you can upload your company logo or favorite image to personalise the screen saver.

The easy-to-use buttons and multi-function control knob make it easy to find the optimal welding parameters for every job. You can either select the settings from the panel manually or allow Weld Assist to select them automatically.

Weld Assist for MMA is a wizard-like function for setting the optimal parameters for each welding job. You just follow simple on-screen steps, selecting electrode type, electrode size, and joint configuration and Weld Assist sets the best parameters for you. It guides every welder towards accurate, productive welding and can be used for pWPS creation, too.

In Master 315 you can select the pulsed MMA welding process to enhance the quality and productivity of your welding. Pulsed MMA brings various benefits for the welder. It lowers the heat input and it gives better control over the welding arc, improving welding speed, providing cleaner welds and reducing heat deformations.



Premium class MMA welding is also characterised by reliable ignition, arc stability and suitability for all electrodes, including cellulosic ones.

Memory channels make it easy to set up the machine for customary welding jobs. The MTP35X control panel offers 99 memory channels per process to save the best parameters or WPS values. You can copy or delete them and update them as needed.

Kemppi UK Ltd
Tel: 0845 6444201
Email: sales.uk@kemppi.com
www.kemppi.com

Overlay welding made easy with the Fronius Compact Cladding Cell

Chemical stress, abrasion and corrosion are a problem for metal parts. However, parts can be protected and their service life increased with the overlay welding of additional special alloys, a technologically sophisticated process. Modern systems, such as the Fronius Compact Cladding Cell, help the user to ensure the requisite high quality.

Overlay welding, also known as cladding, is a method of repairing metal components or protecting them from abrasion and corrosion by applying a filler material. During this process, parts made of inexpensive steel grades are clad with special alloys such as Alloy 50, CrMo 910 or Inconel 625. The combination of an inexpensive base material and a high-quality protective coating delivers significant cost advantages. Typical areas of application are the petrochemical, aerospace and power generation industries.

Compact platform for diverse part geometries

Fronius has taken a compact and simple solution for cladding applications on smaller parts and developed it for larger tasks. The second generation of the Compact Cladding Cell offers space for components with a diameter of up to one metre and a maximum weight of 2,500 kg. The maximum part height of 1.4 m can be increased to 1.9 m. In addition, the system enables the surfacing of a wide range of bore geometries, cylindrical, conical, multi-diameter, etc, from a bore diameter of 25 mm. The possible applications are diverse and include riser pipes and valves for underwater components in the oil and gas industry, for example blow-out preventer stacks, pump parts, rollers, casting moulds and other highly stressed parts.

The Compact Cladding Cell is

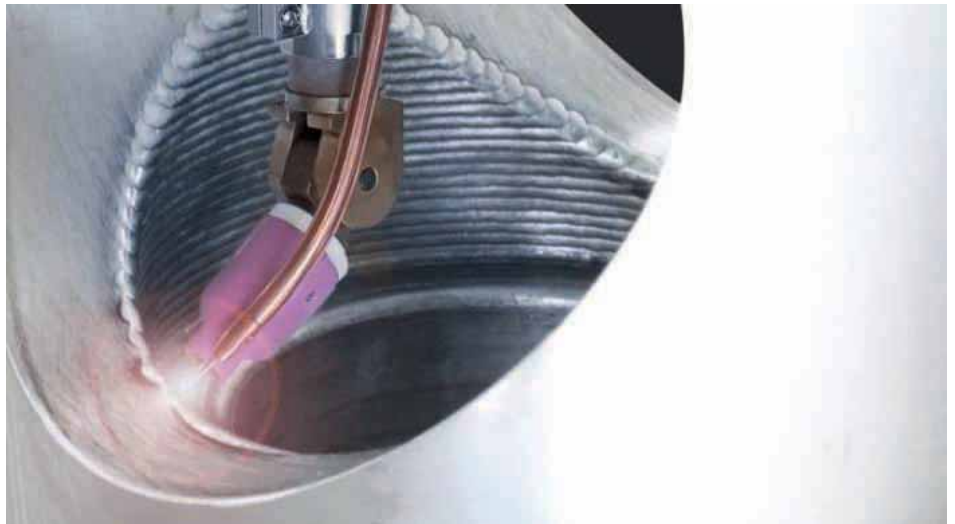

cost-effective and space-saving, with the platform measuring less than 6 sq m, with enclosure approx. 10 m². All components are pre-installed and can therefore be quickly assembled and put into operation. In addition, the entire system uses a single power supply, which makes installation much easier. Fronius has also designed the system so that users can work as comfortably and ergonomically as possible, such as when changing the wire spools.

The ultimate welding technology

The highly developed Fronius welding technology and seamless digital communication between system controls and power source guarantee high process reliability. Customers can choose between the TIG hot wire and the SpeedClad Twin process. SpeedClad Twin is also based on the TIG hot wire process, but with two tungsten electrodes and two wires it achieves welding speeds up to three times faster than the conventional TIG hot wire process from Fronius.

The fact that all system modules are optimally matched to each other further supports the quality of the welding results. The horizontal rotary table ensures precise positioning of the part. The stand arm boom in turn allows horizontal pendulum movements and enables the different welding torches to be fitted, from various internal cladding torches, to a ring groove welding torch, to the SpeedClad Twin

welding torch. The wirefeeder with double wire option and 4-roller drive operates synchronously and delivers absolute reliability, using both the Fronius TransTig 5000 and TransTig 2200 power sources with the latter being responsible for preheating the welding wire. The two devices are required in a twin setup for the SpeedClad Twin process.

New system controls for user-friendly operation

The new HMI T21 system controls provide added operator convenience. The mobile control panel with its 21-inch touchscreen enables clear and straightforward operation, while the software facilitates intuitive programming and control of all system components. Welding programs can be easily created with graphic support. The 3D real-time visualisation combined with actual value monitoring simplify precise monitoring of the welding process, including all relevant welding parameters. In addition, it is possible to create different users and assign individual authorisations on the system controls. Furthermore, the HMI T21 offers the option of remote system maintenance.

Fronius UK Ltd
Tel: 01908 512300
Email: info-uk@fronius.com
www.fronius.co.uk

123insight INFO Exchange

The new online way to evaluate MRP

Regular sessions

90 minutes

Free to attend

**See what a manufacturing system *should*
be doing for your business.**

At 123 Insight we've always done things differently. Due to COVID-19, we've created a new online event.

The 123insight online INFO Exchange is a free to attend manufacturing companies' online interaction from which you will gain a better understanding of what MRP can do for your business. This regularly held group online session lasts for around 90 minutes, during which you will see software demonstrated and get to understand the 123insight difference. There's a Q&A session, so you'll also get to hear from other companies, often asking questions that you may not have even considered! You'll also receive a free copy of our book '*How to implement a manufacturing system*' just for attending.

Alternatively, register to get instant access to our online Demo Movies, broken down by job role, which explain what 123insight will do for each department in your business.

Book to attend at [123insight.com](https://www.123insight.com)

**Advanced
Simplicity®**

123 Insight Limited
01489 860 851
info@123insight.com www.123insight.com



DON'T LET YOUR INVESTMENT GO UP IN FLAMES!



 **kraft & bauer uk**

AUTOMATIC FIRE SUPPRESSANT SYSTEMS
(WILL FIT TO ANY MACHINE)

Kraft & Bauer UK Ltd
Unit 80 Hotchkiss Way, Binley Industrial Estate, Coventry. CV3 2RL
(t) 02476 22 94 77

www.kraftandbauer.co.uk

(e) sales@kraftandbauer.co.uk